

SFR200

Handleiding montage / onderhoud / demontage
Manual fitting / maintenance / dismantling
Anleitung Montage / Wartung / Demontage
Manuel montage / entretien / démontage
Manual montaje / mantenimiento / desmontaje
Manuale di installazione / manutenzione / smontaggio
Instrukcje montaż / konserwacji / demontażu
Návod montáž / údržba / demontáž



Contents

1.	Symbols	3
2.	General warnings	3
2.1	Safety requirements for assembly and first use	3
3.	Terms and conditions	3
4.	Area of application	3
5.	Guidelines	4
6.	Fixing material building	4
7.	System summary	5
7.1	Pre-assembled rail set	5
8.	Fasteners/ tools	6
9.	Assembly	7
10.	Handover	35
10.1	First use	35
11.	Electric operator (optional)	35
11.1	To adjust the operator	35
12.	Disassembly	35
12.1	Disposal	35
13.	Maintenance	36

1. Symbols



Danger



Attention



Additional manuals

2. General warnings

This manual has been prepared for use by qualified personnel and therefore not by trainees or “do it yourselfers”
In case of doubt about the assembly and/or maintenance, please contact DOCO International
To avoid severe personal injury, carefully read and observe all indications and warnings in this manual.

- This manual describes the assembly, use and maintenance of your residential system /door SFR200; this may be supplemented by other manuals, for instance the spring break device manual and operator manual (if applicable.)
- This residential system has been designed in accordance with the latest European standards; however you have to check yourself whether this standard corresponds with the local national standard.
- All measurements are in millimetres unless otherwise specified.
- After installation ensure that the CE marking label has been completed and attached.
- Keep this manual in a safe place.
- Subject to technical changes, without written notice.

2.1 Safety requirements for assembly and first use.

- This residential system may only be mounted, connected and put into operation by qualified personnel.
- Make sure that the power is switched off and remains switched off while electrical work is carried out!
- Never bridge safety devices !
- Adding or leaving out parts can affect the door operation in a negative way and therefore the safety of the installed sectional door. This is therefore strongly discouraged!
- Some parts can contain sharp edges: use protective gloves.
- All references to the door/component handing within this manual is always as viewed from inside looking out.
- Never use the sectional door in case of or visual damage on the safety devices.
- When performing assembly/maintenance, always wear at least gloves and safety boots and during drilling/cutting wear safety goggles!
- Make sure that you can always perform your work in a stable environment.
- Secure the assembly/maintenance site with safety ribbon to keep others (children!) at a distance.
- Maintenance must only be performed by a qualified company and/or qualified personnel.
- Make sure there is enough light.
- Only use appropriate tools, especially when tensioning the torsion springs.

3. Terms and conditions

Our general conditions of delivery and payments are applicable on all our offers, agreements or subsequent revisions.
A copy of our terms and conditions are available on request or can be downloaded from our website: www.doco-international.com.

4. Area of application

This hardware set has been developed for installation in garages in the private sector

- Maximum width 5000 mm
- Maximum height 3000 mm
- Weight door leaf maximum 165 kg
- Maximum temperature range outside* : -20 degr until + 50 degr C
- Relative humidity 20 – 90%
- Lifetime : 25.000 cycles (unless the torsion springs have been calculated for this)

* big differences in temperature between the inside and outside can cause deflection in the panel leafs (bi-metal effect). In particular dark coloured panels are susceptible to this problem and should be avoided. Care should be taken during manual handling as there is a big risk of damage.

5. Guidelines



DOCO International had carried out the “Product Test“ of this door (Initial Type Testing = ITT) by the SP institute in Sweden, known as Notified Body No. 0402.

Documents regarding this ITT can, in consultation with DOCO, be transferred to the company which produces the door. This is necessary to complete a CE-dossier.

NOTE: CE-approved only using the correct DOCO-components.



It is the responsibility of the installation company to ensure that the chosen E-operator and panels conform to the product standard EN13241-1 and have carried out the necessary ITT.

If a wicket door is to be installed, it is the responsibility of the installation company to ensure that the complete door conforms to the product standard EN13241-1 and have carried out the necessary ITT.

6. Fixing material building



The necessary fixings to ensure the garage door to the building and/or ceiling, are not included!

It is the responsibility of the installer to make sure that the building structure is safe/strong enough, to accept the door and its fixings.

The installer is also responsible for using the correct fixing materials on the right foundation (stone, concrete, steel, wood).

In the image section there will be therefore no specification included.

7. System overview

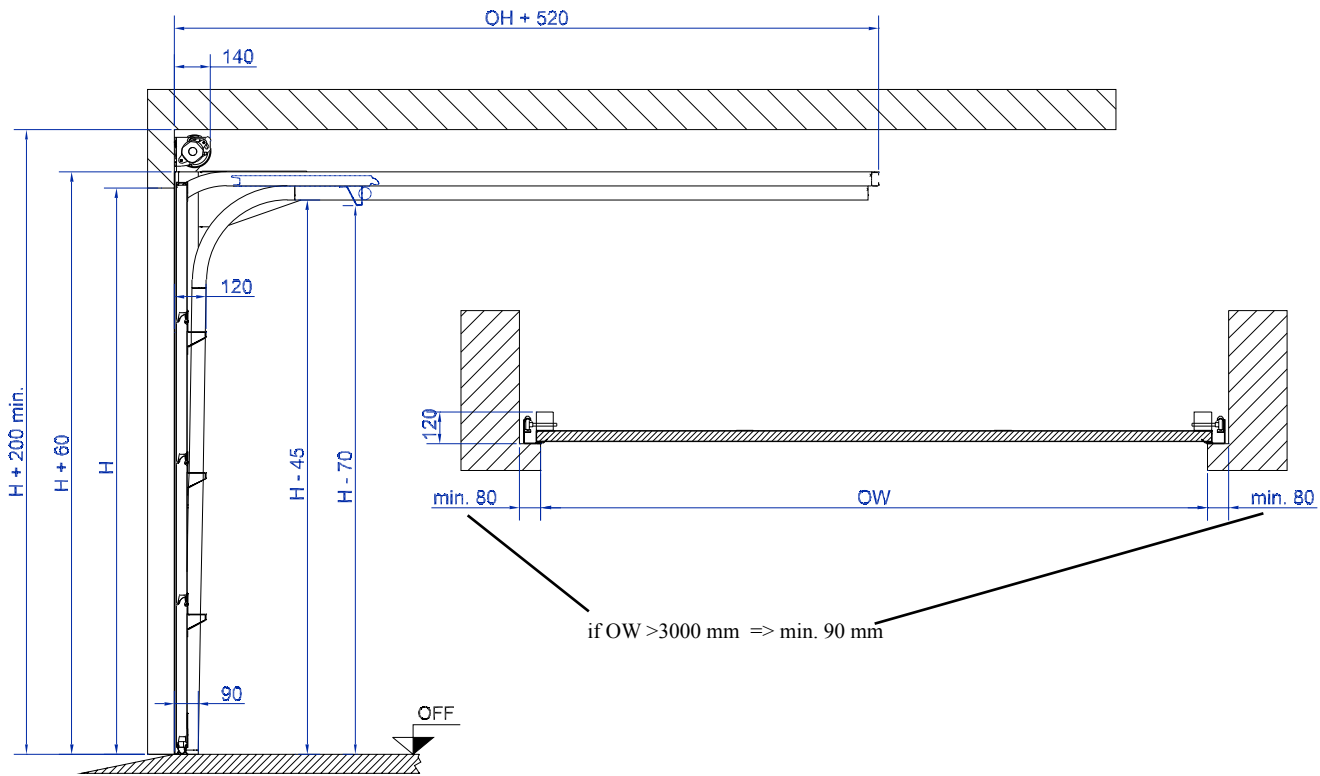

7.1 Pre assembled track sets overview SFR 200 system



Horizontal trackset SFR 200 (Pair)

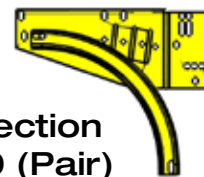

Curve section SFR 200 (Pair)



Verticale trackset SFR 200 (Pair)

Daylight height (H)	Verticale trackset SFR200 (Pair)		Horizontal trackset SFR200 (Pair)		Curve section SFR200 (pair)
	Bolt version	Rivet version	gebouten versie	Rivet version	Rivet version
	Article	Article	Article	Article	Article
2000	45000-2000	45010-2000	45001-2000	45011-2000	45012
2125	45000-2125	45010-2125	45001-2125	45011-2125	45012
2250	45000-2250	45010-2250	45001-2250	45011-2250	45012
2375	45000-2375	45010-2375	45001-2375	45011-2375	45012
2500	45000-2500	45010-2500	45001-2500	45011-2500	45012
2750	45000-2750	45010-2750	45001-2750	45011-2750	45012
3000	45000-3000	45010-3000	45001-3000	45011-3000	45012

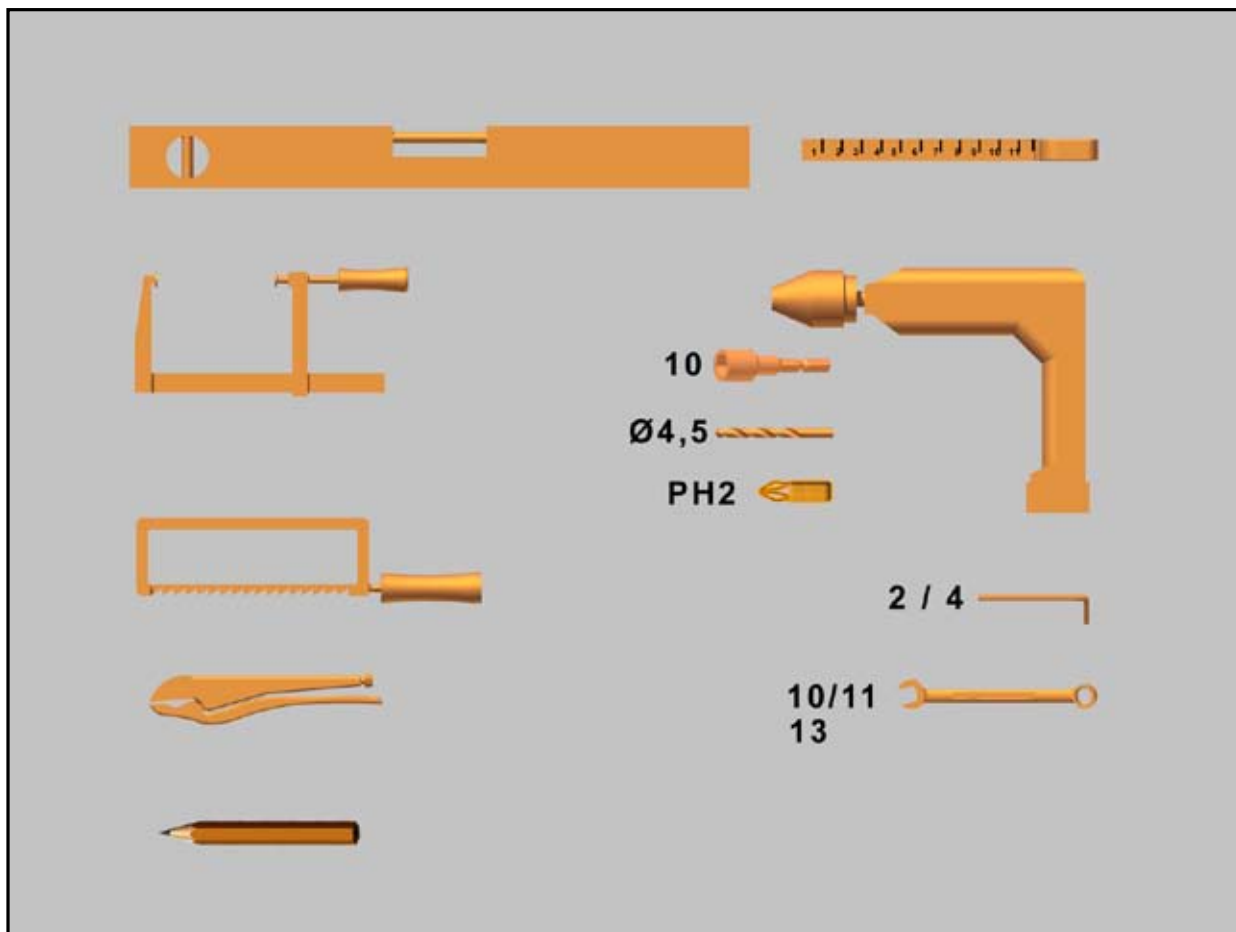
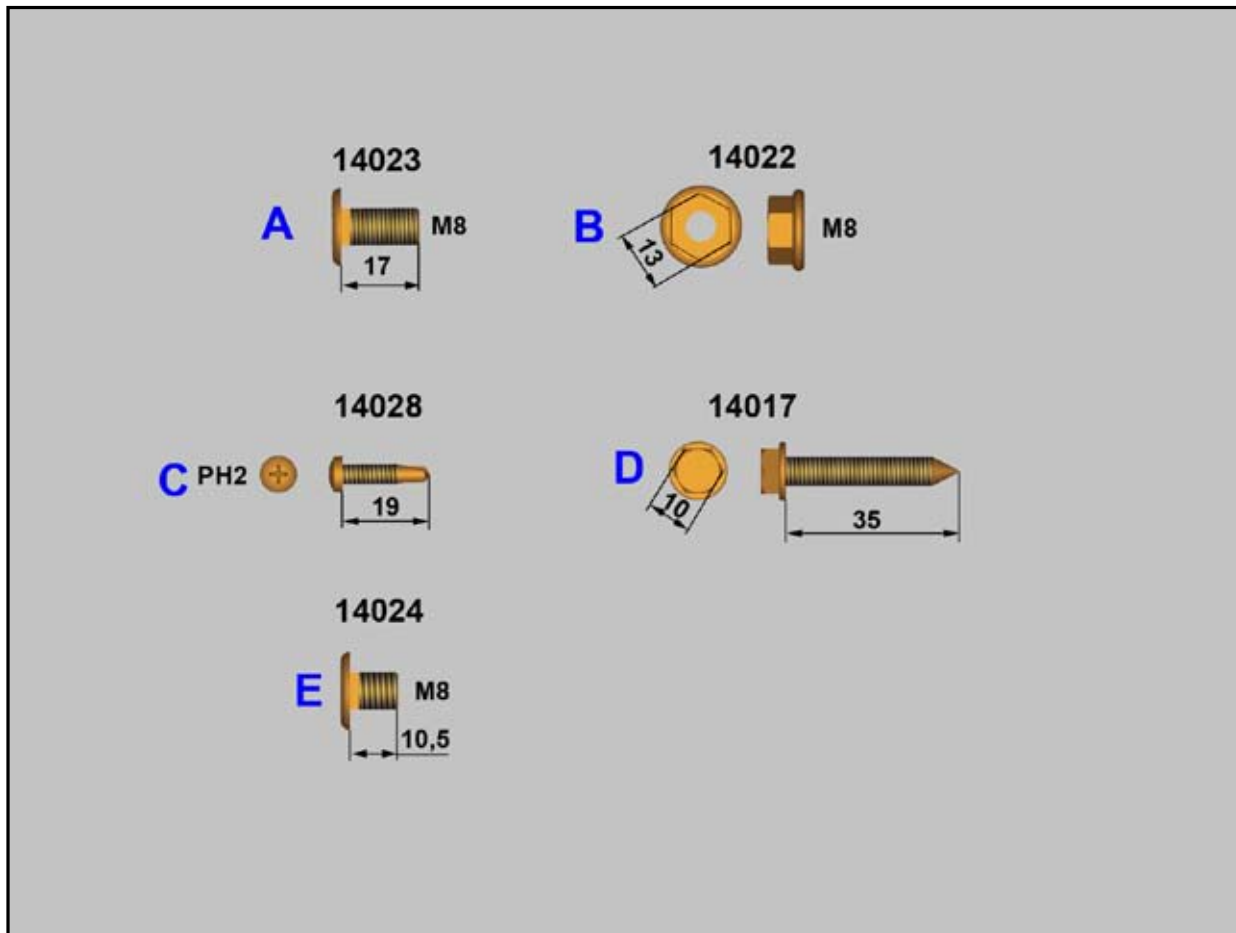

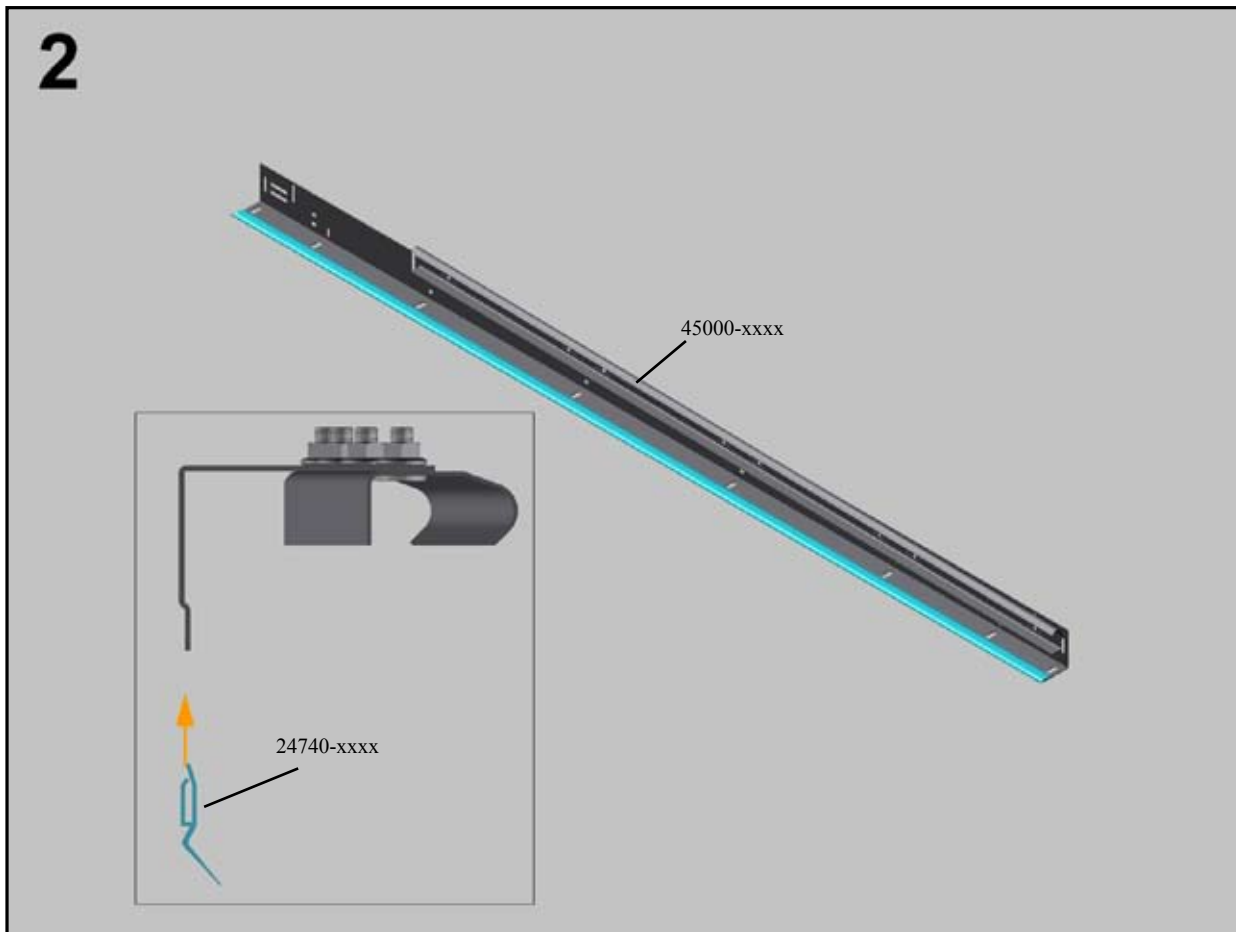
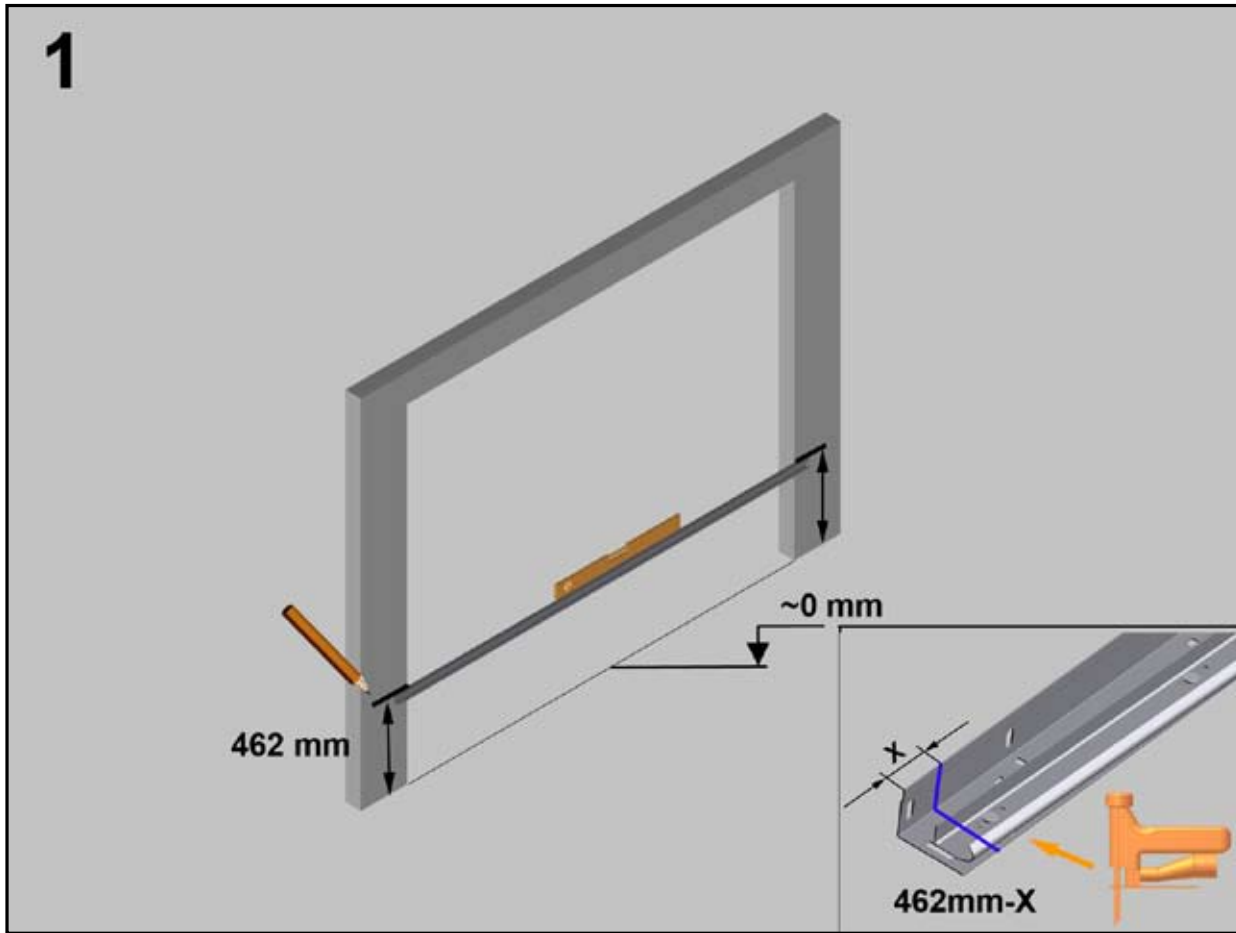

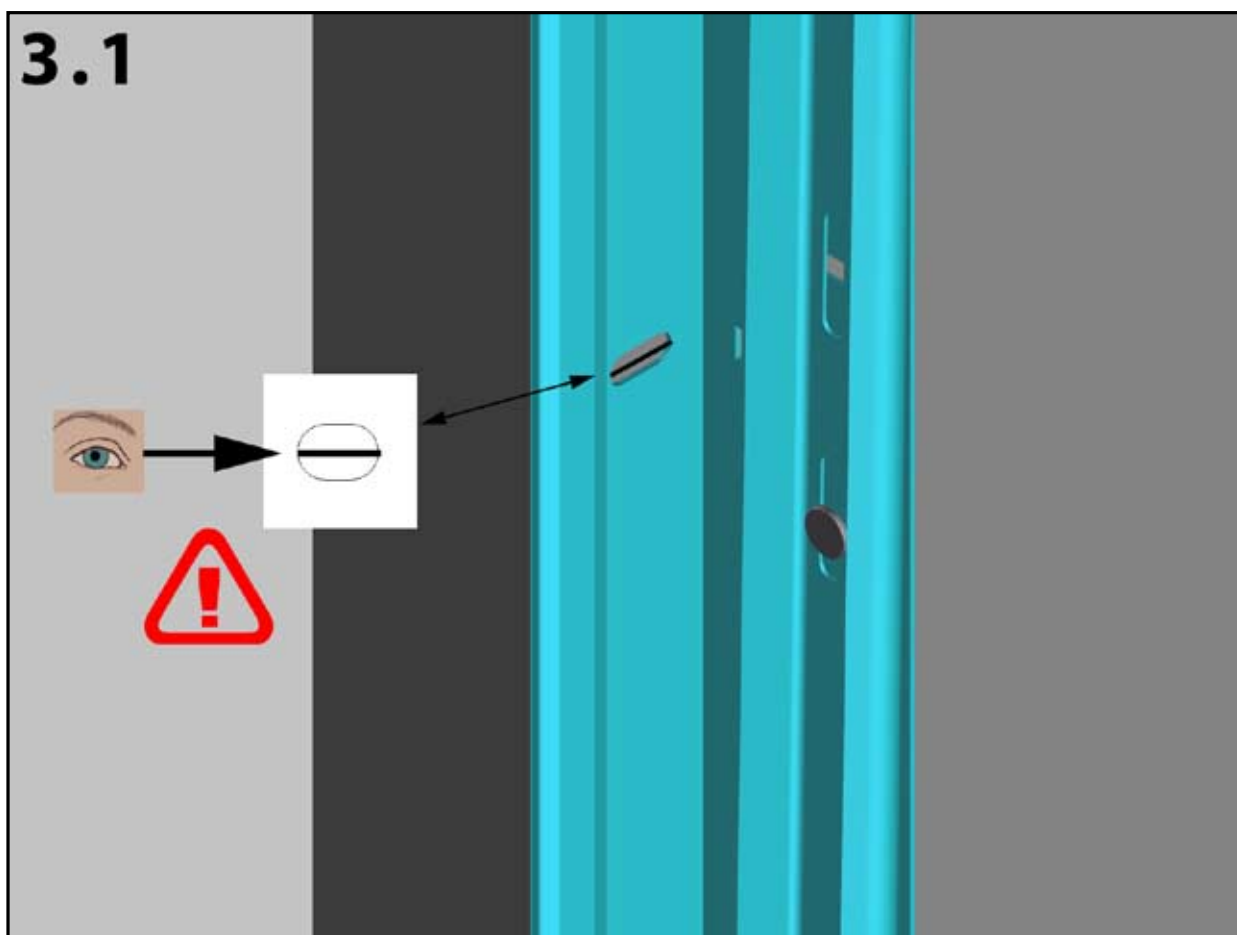
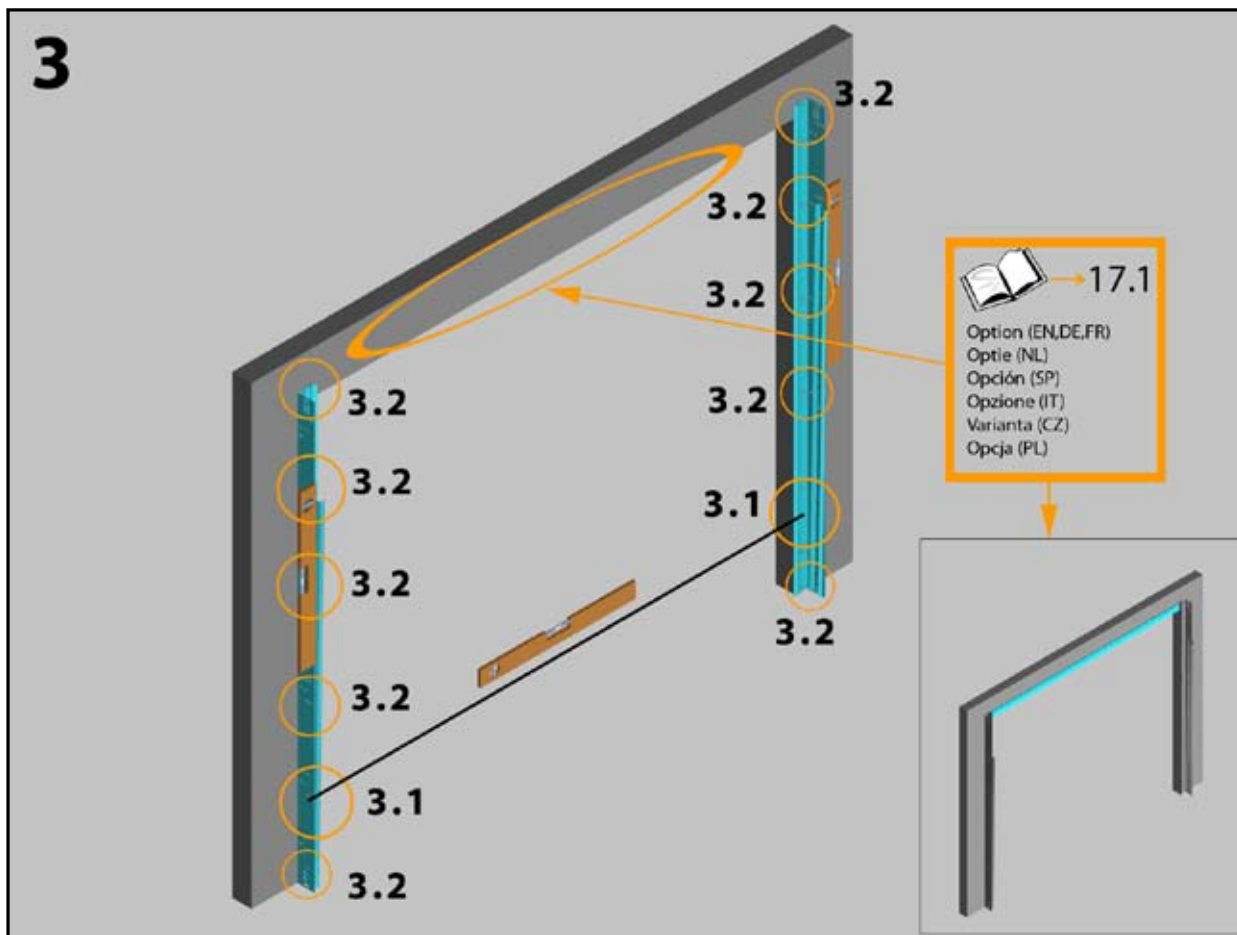

3.2

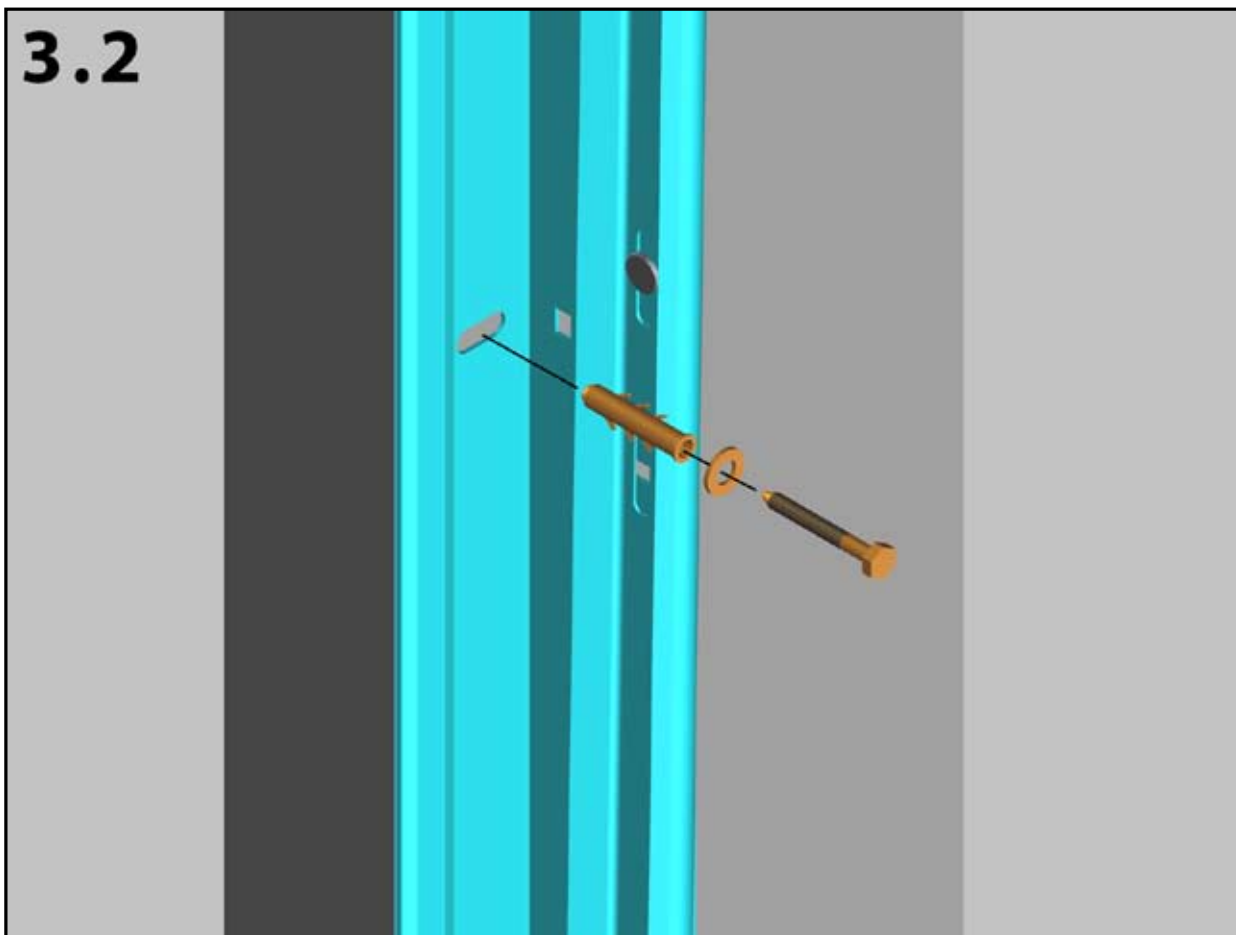

4

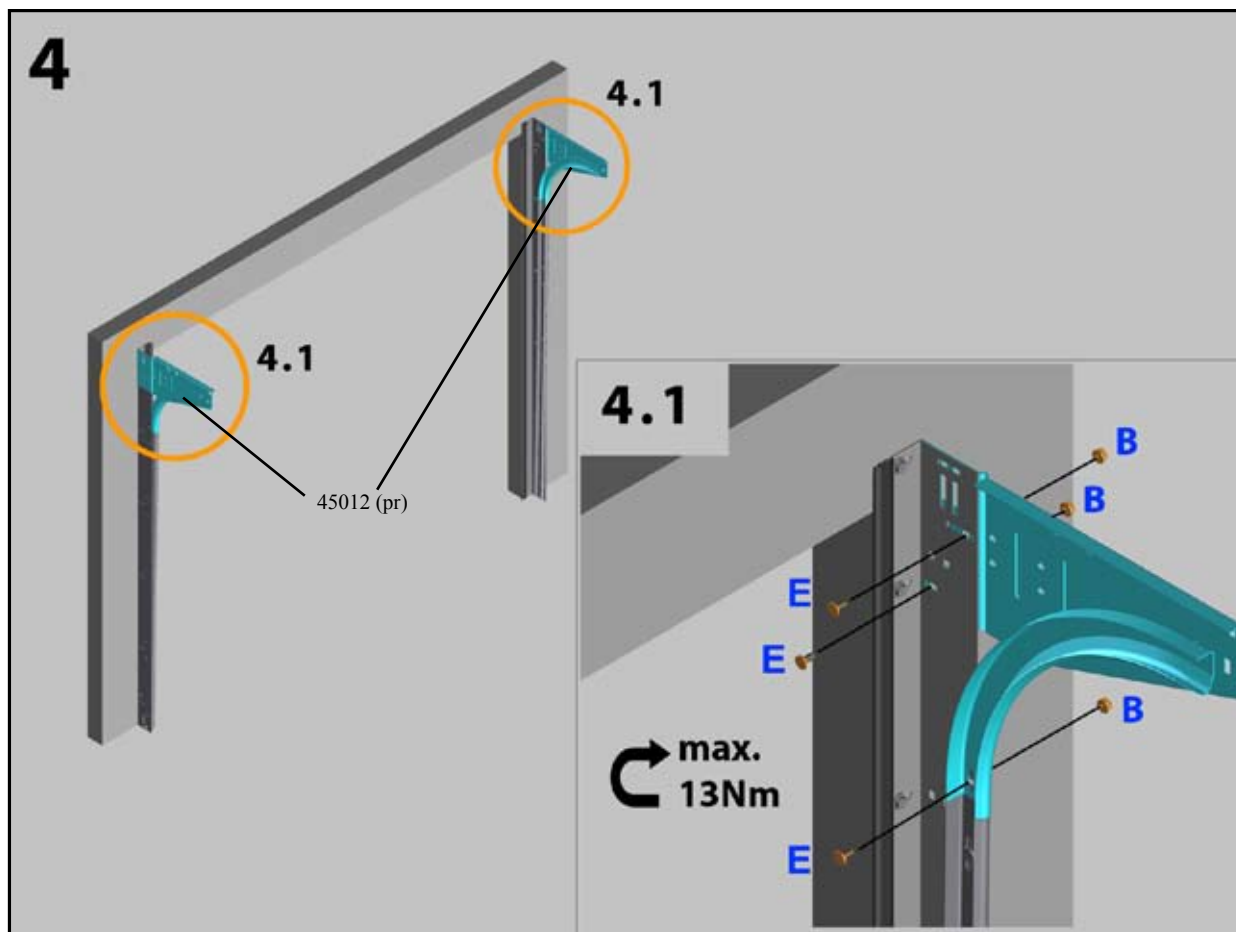

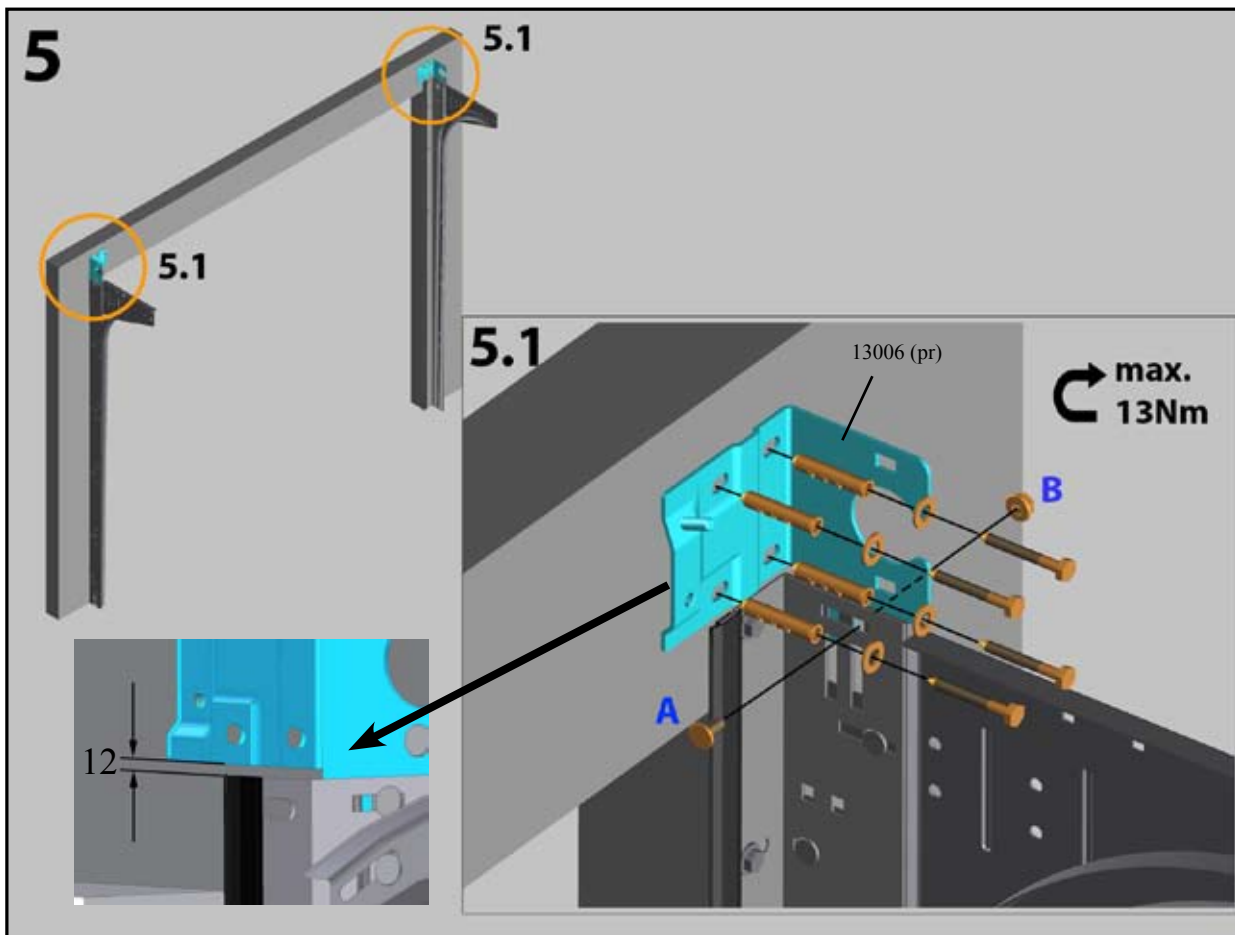

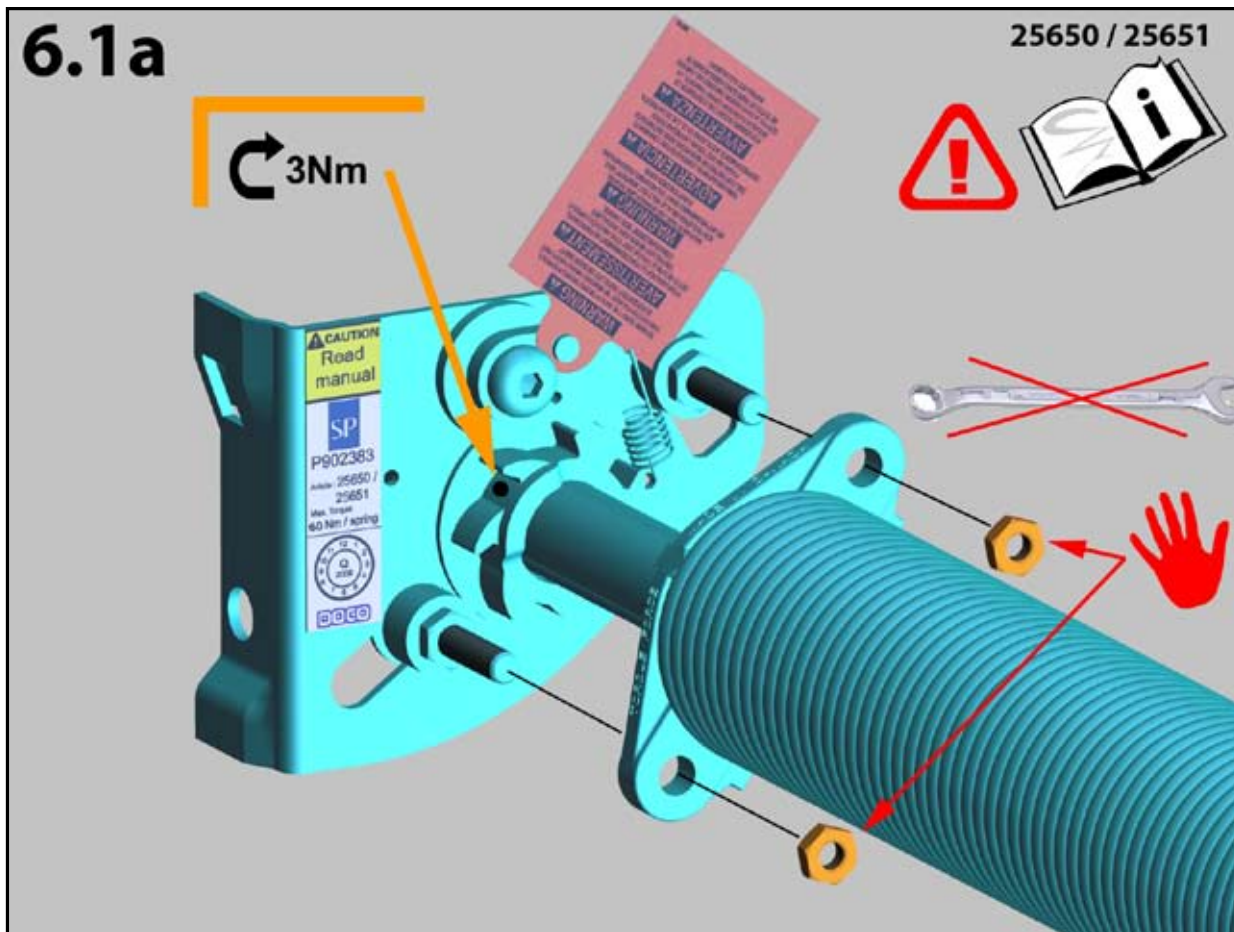
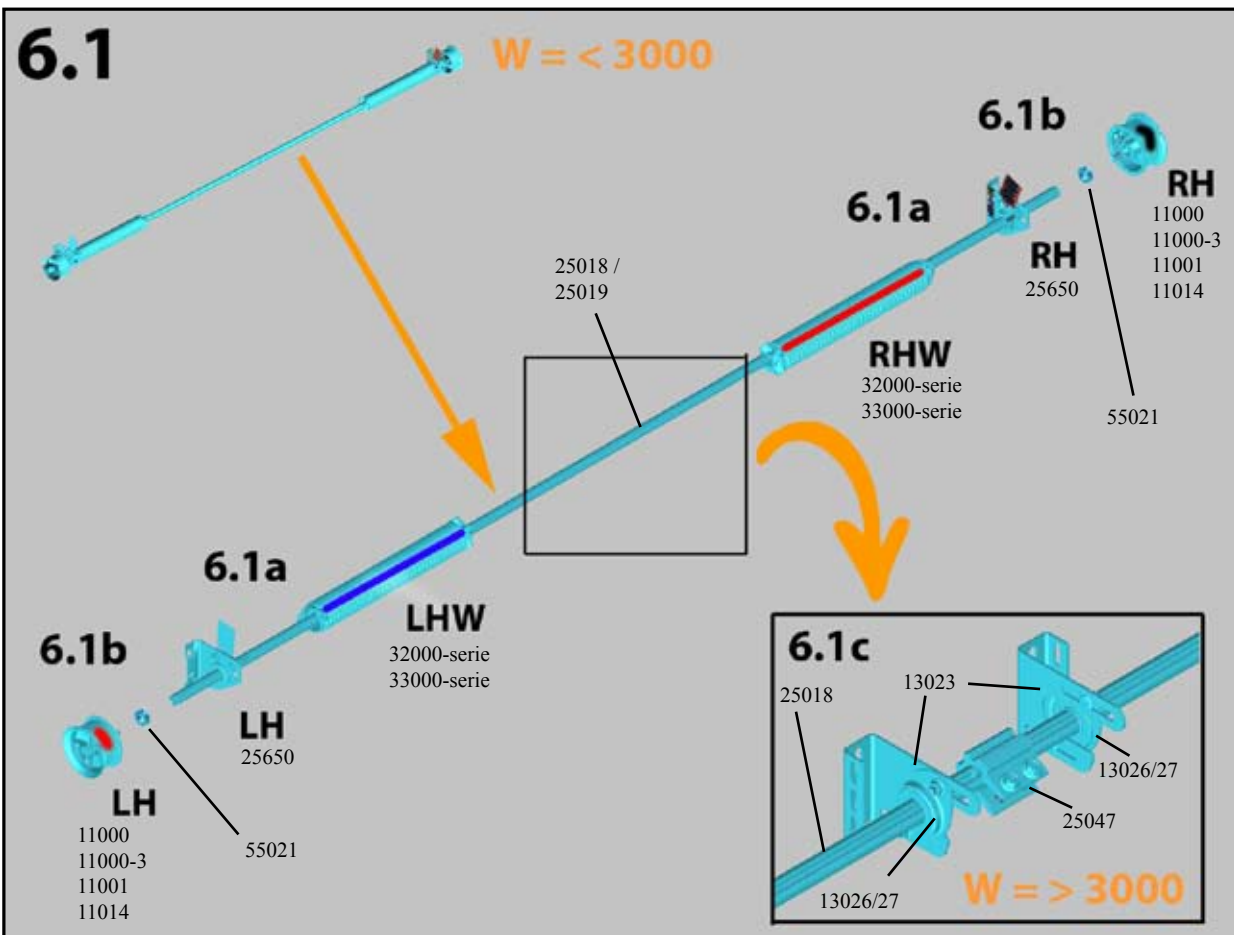

6.1b

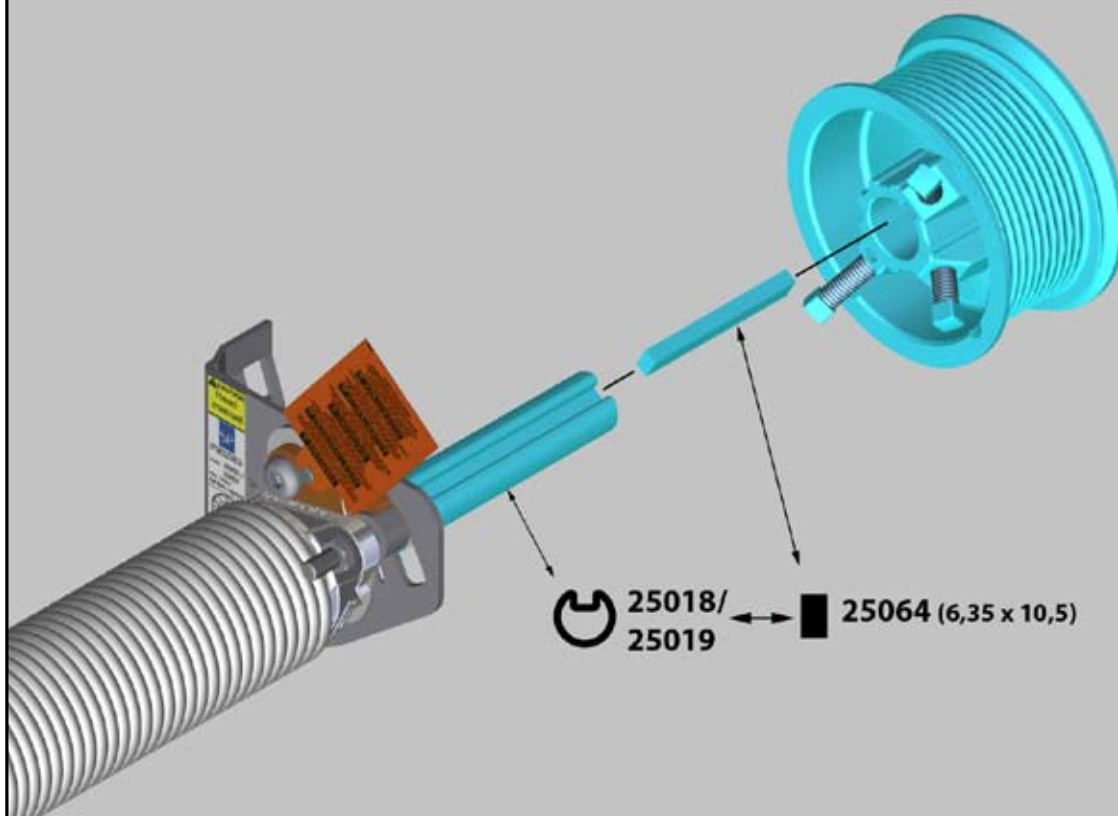

6.1c

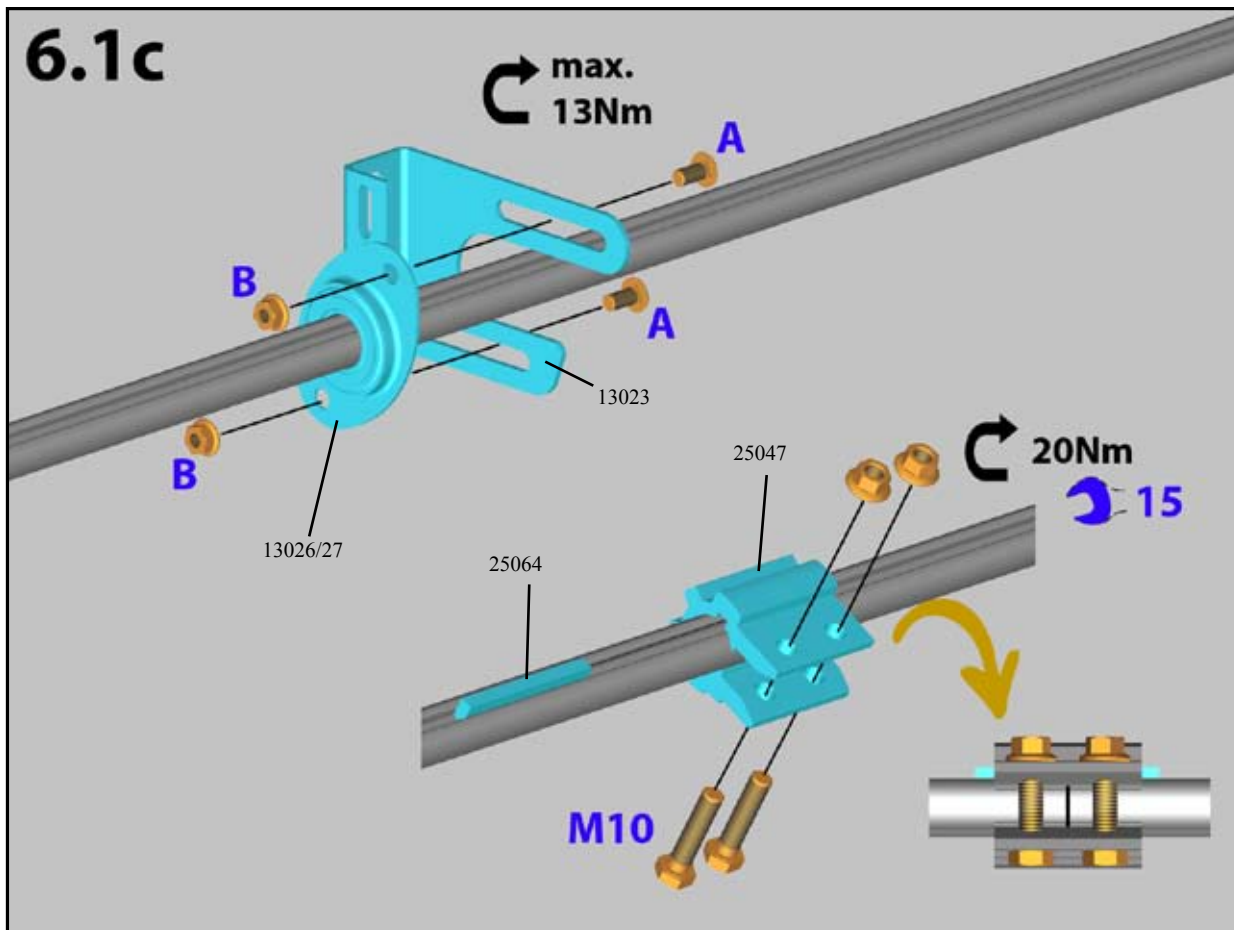

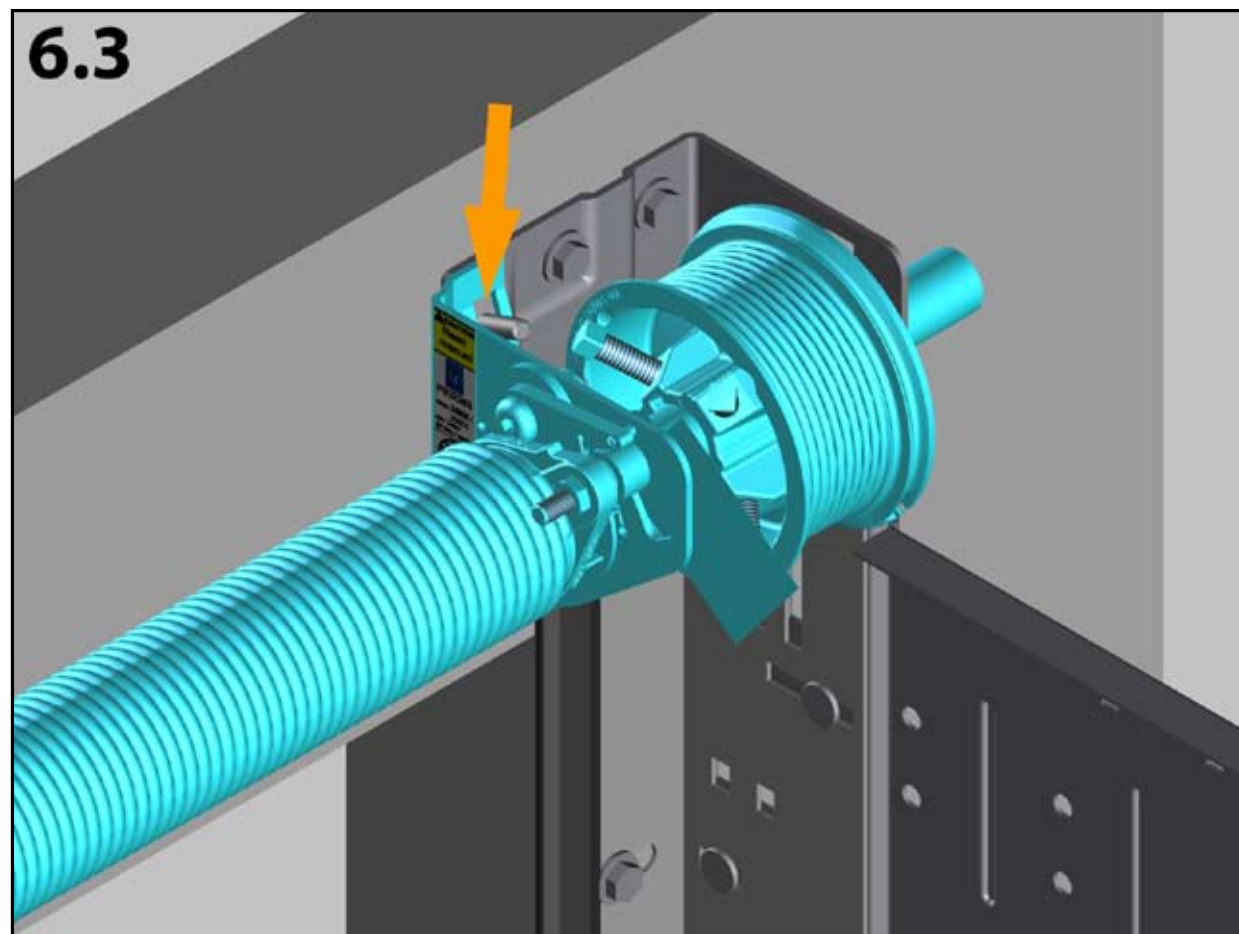
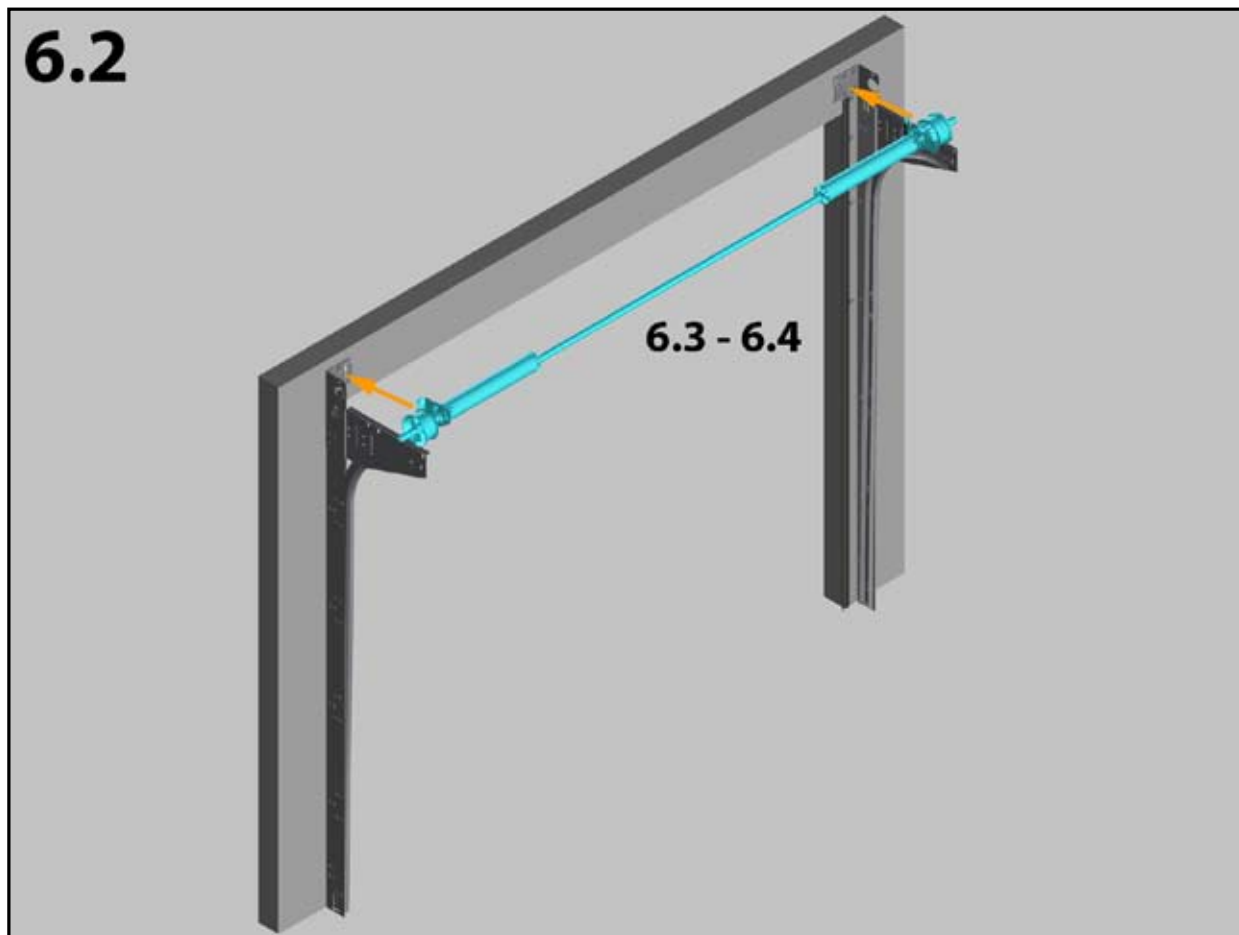

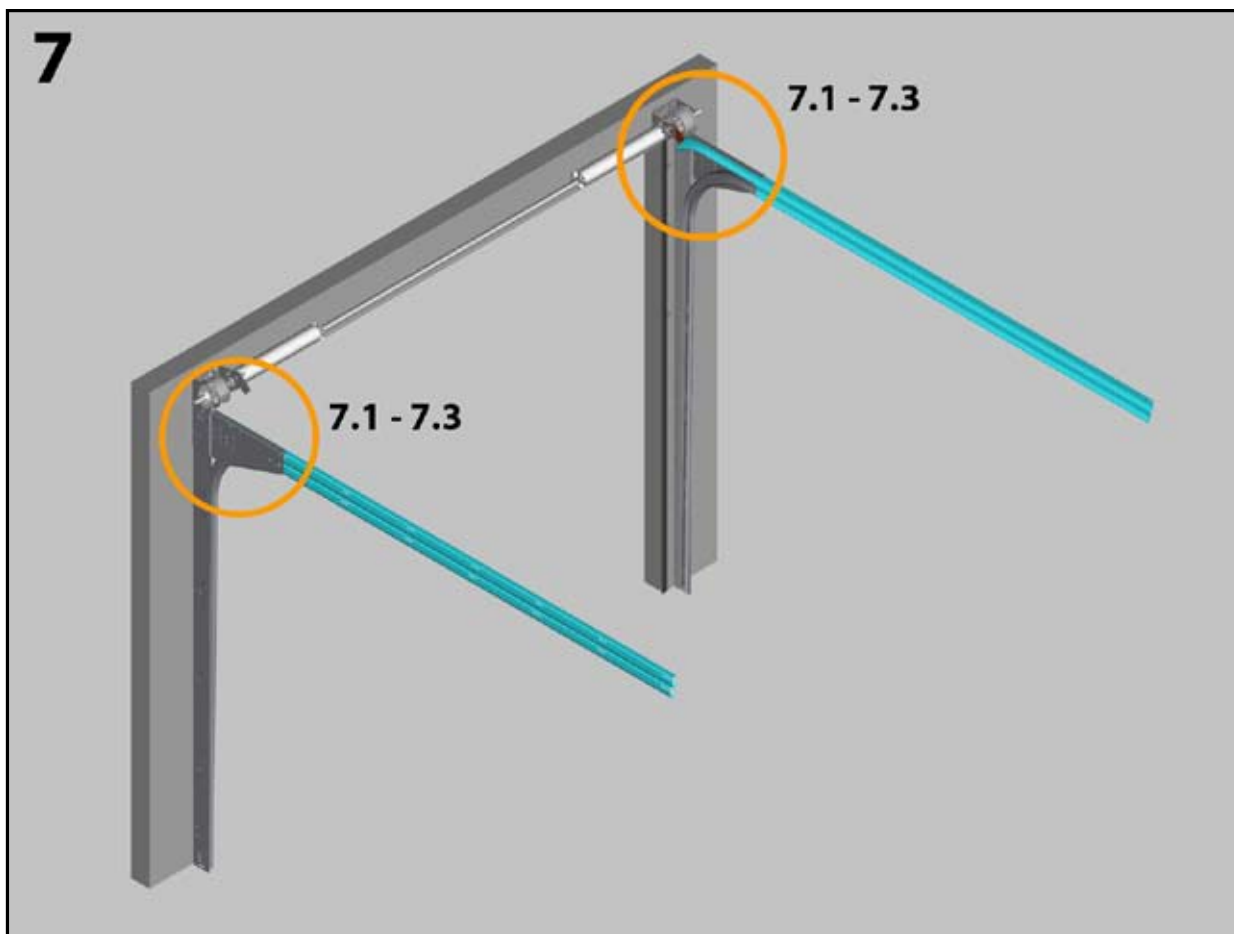
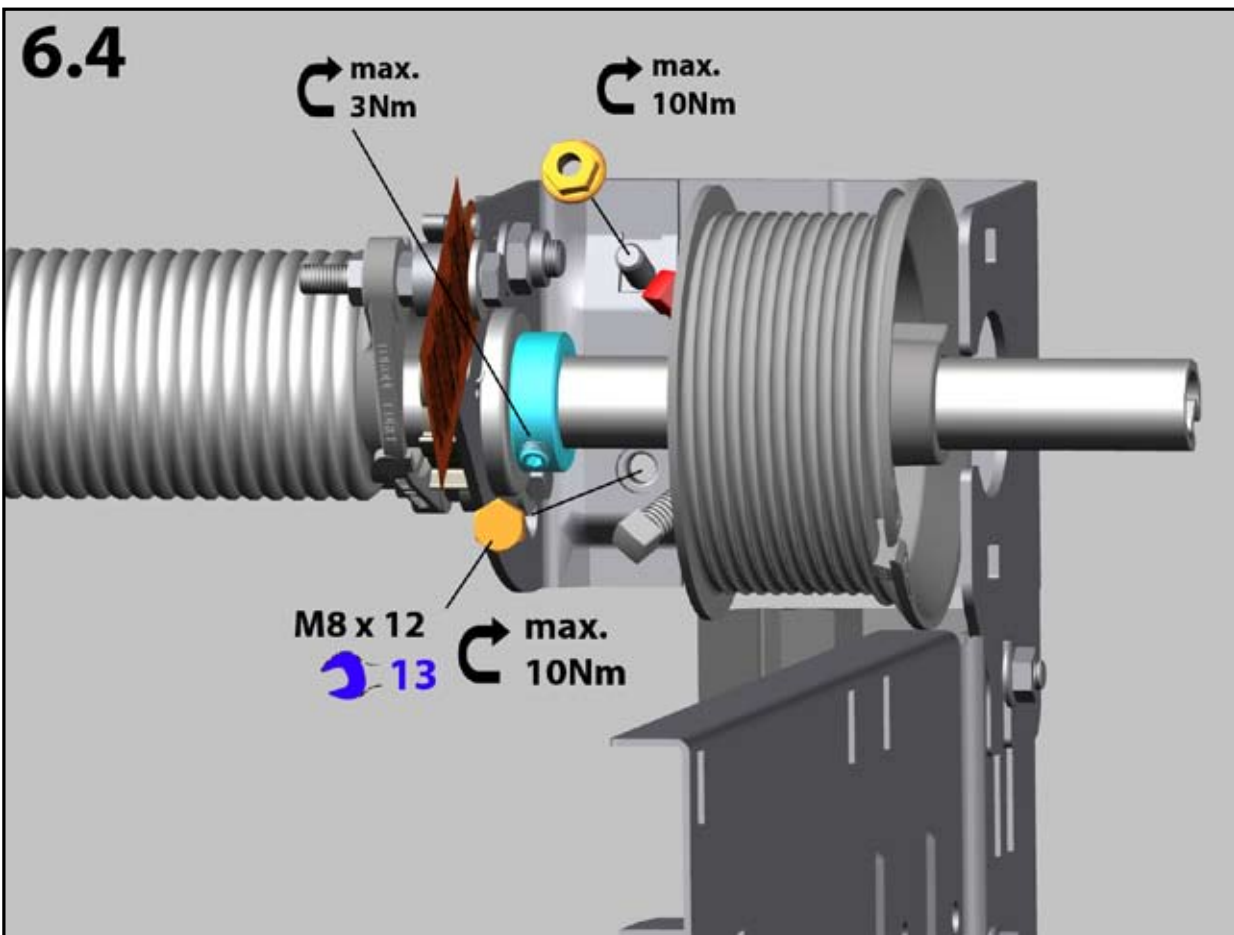

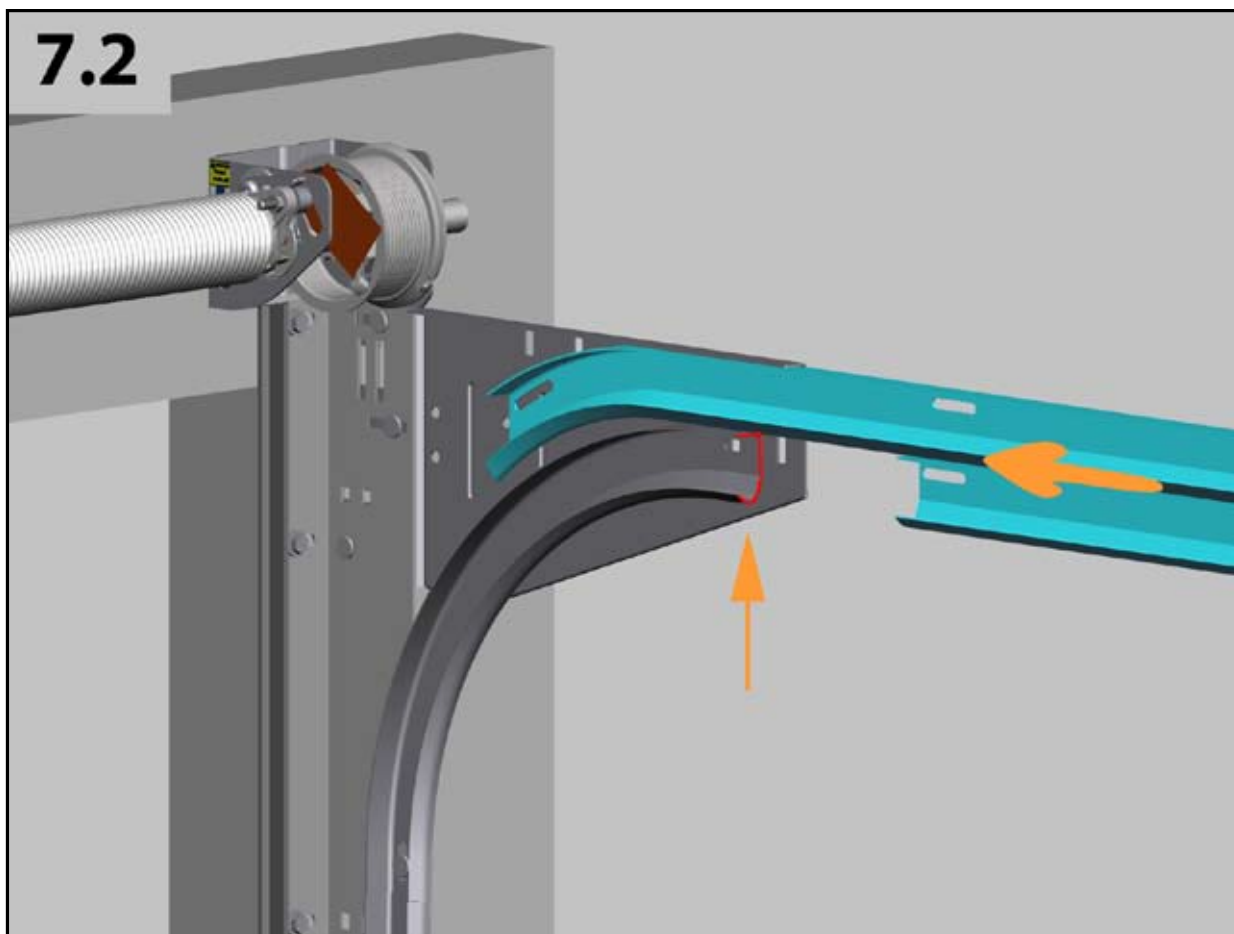
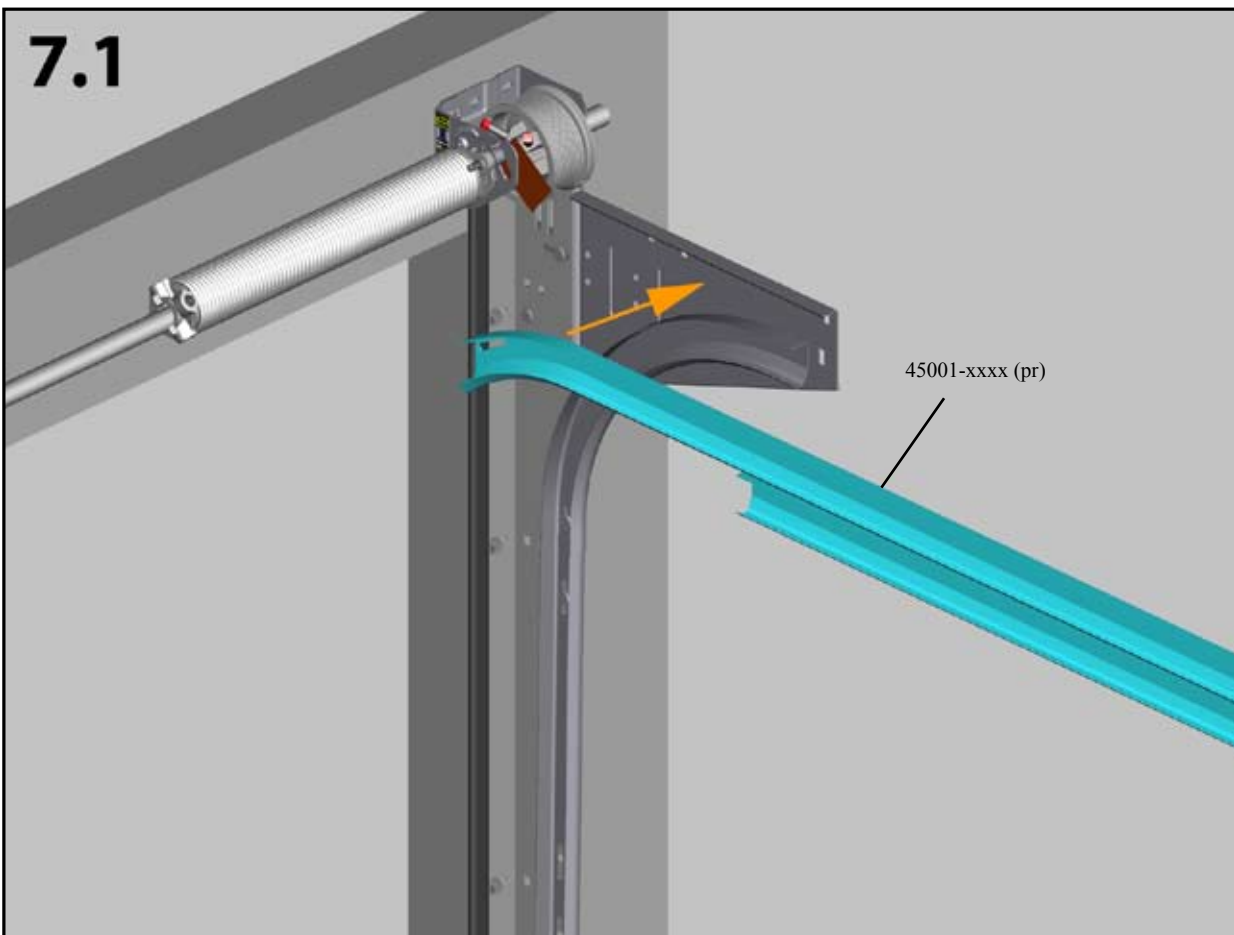

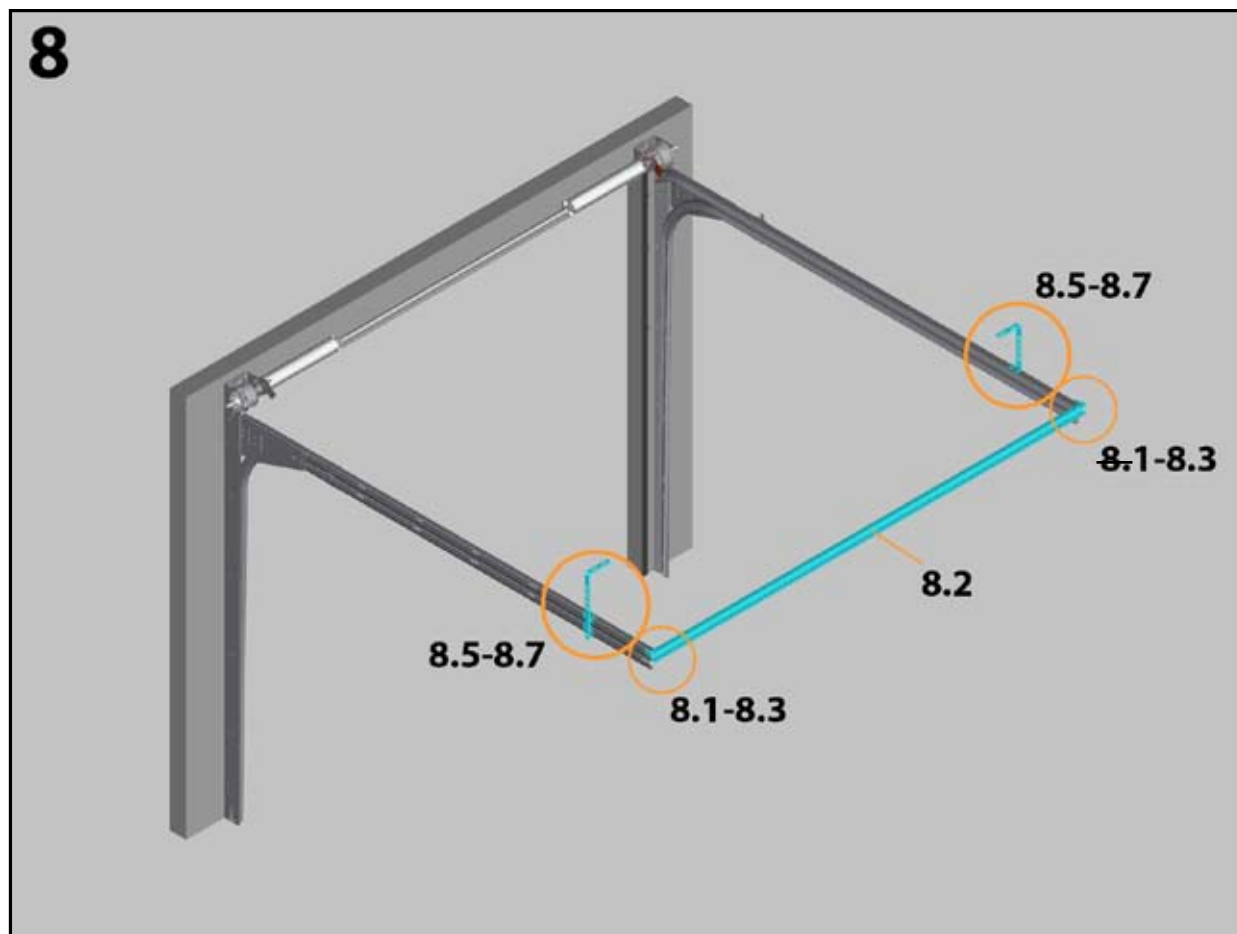
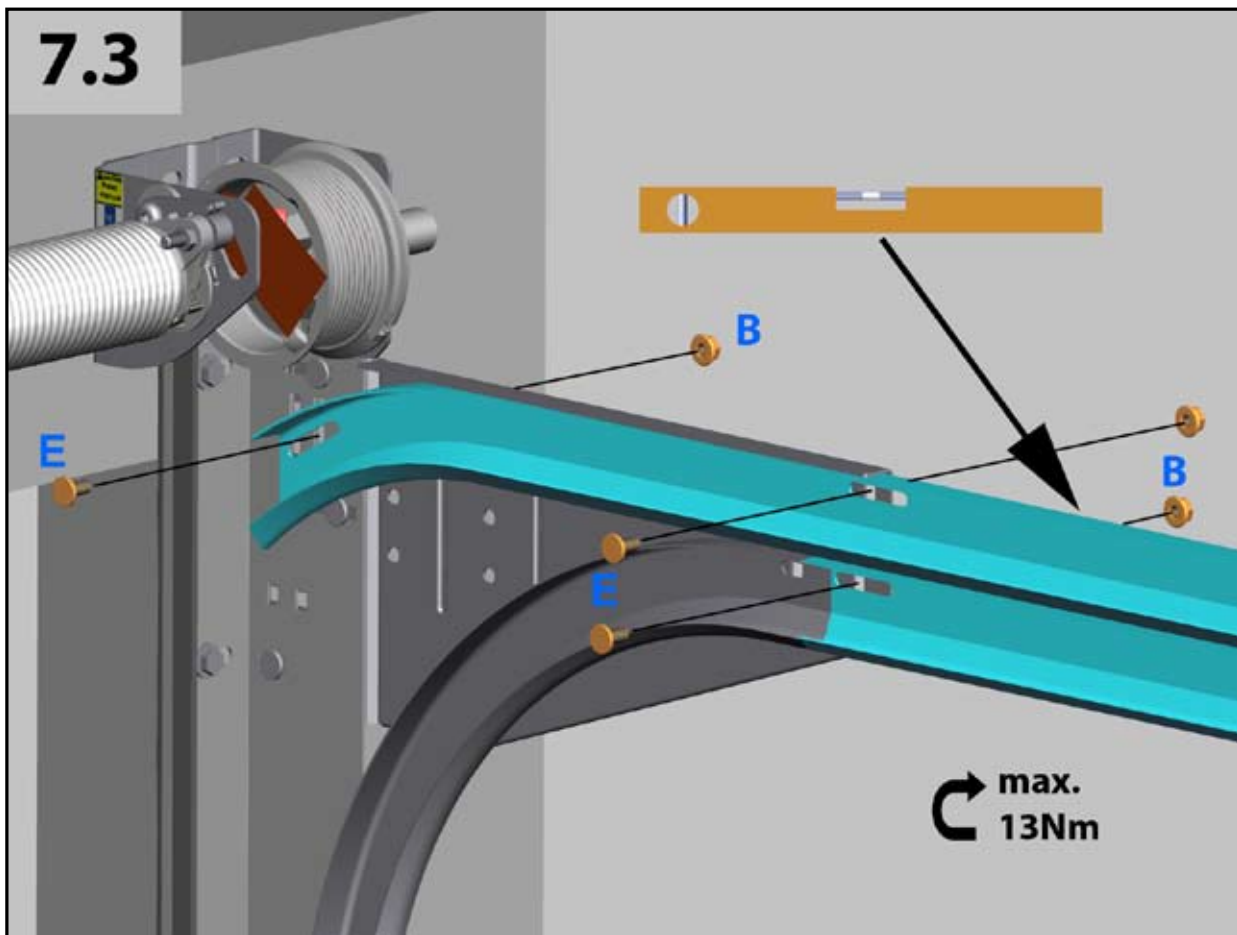

8.1

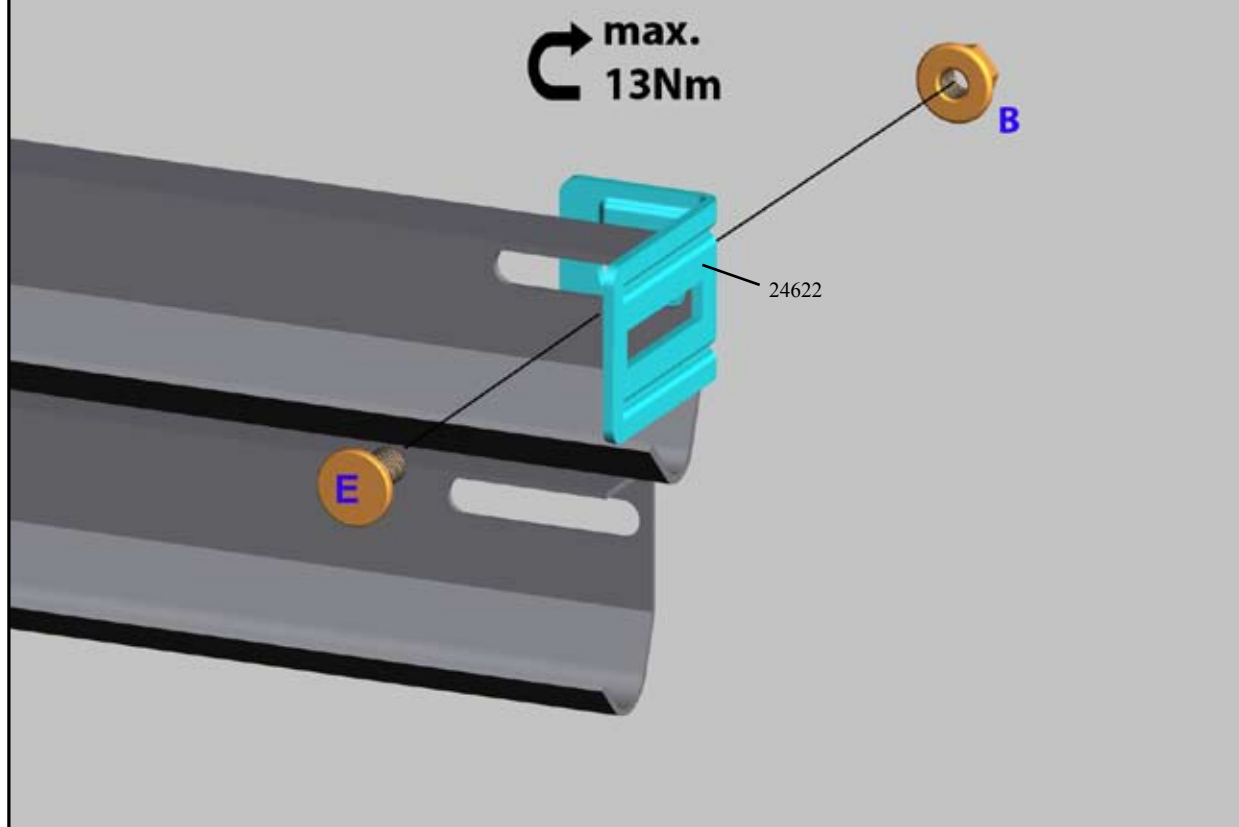

8.2

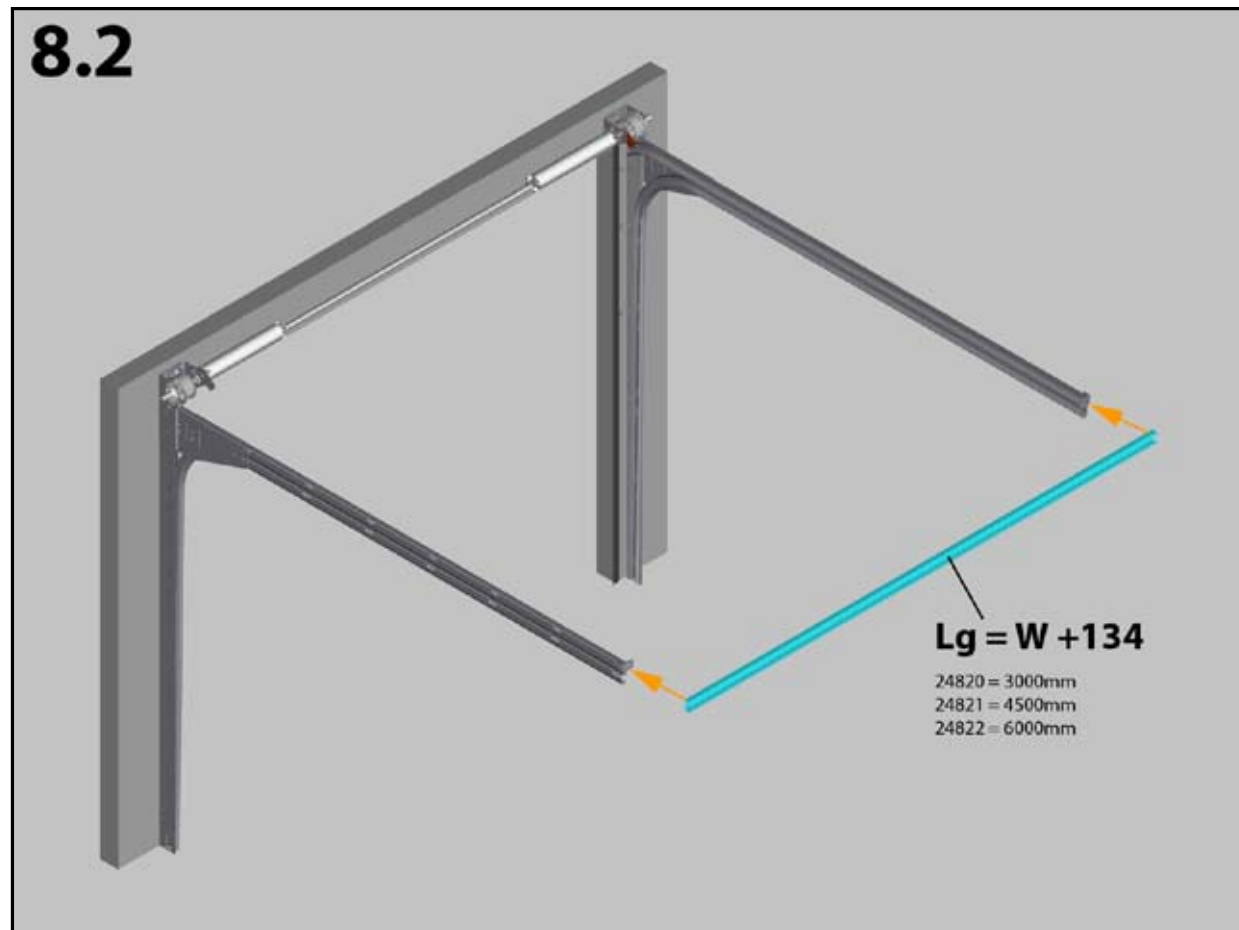

8.3

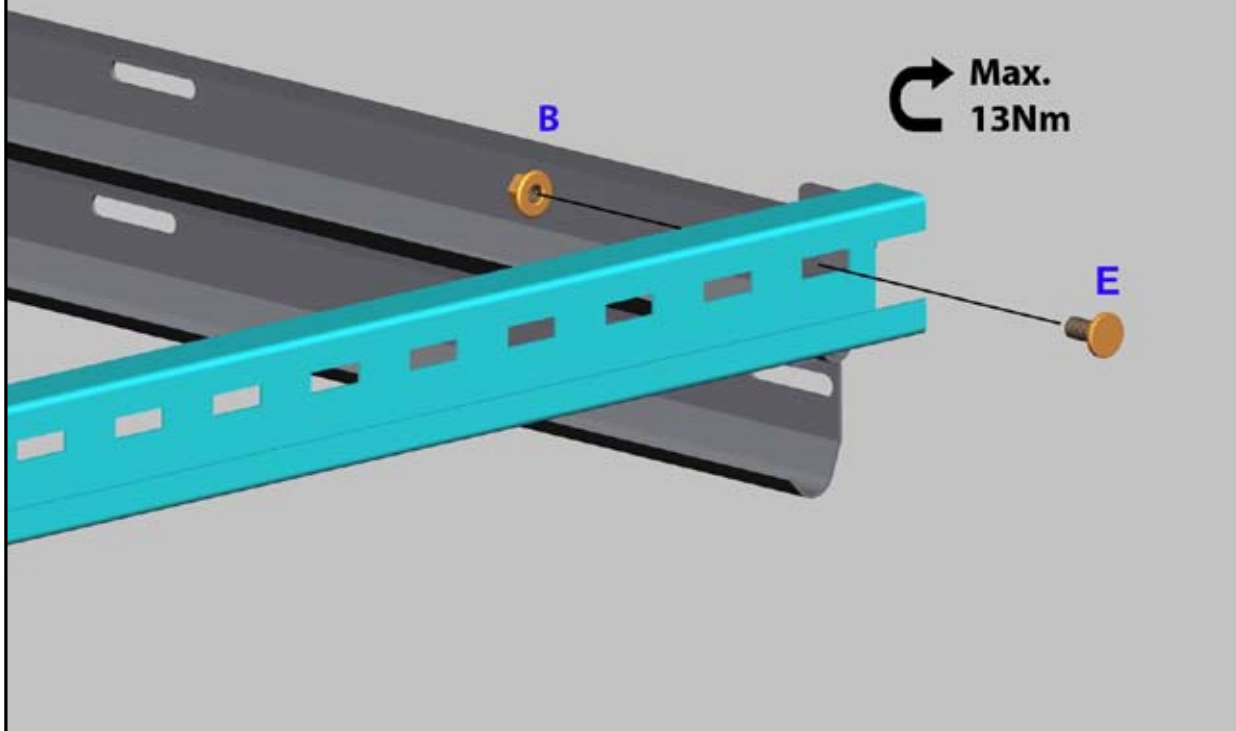

8.4

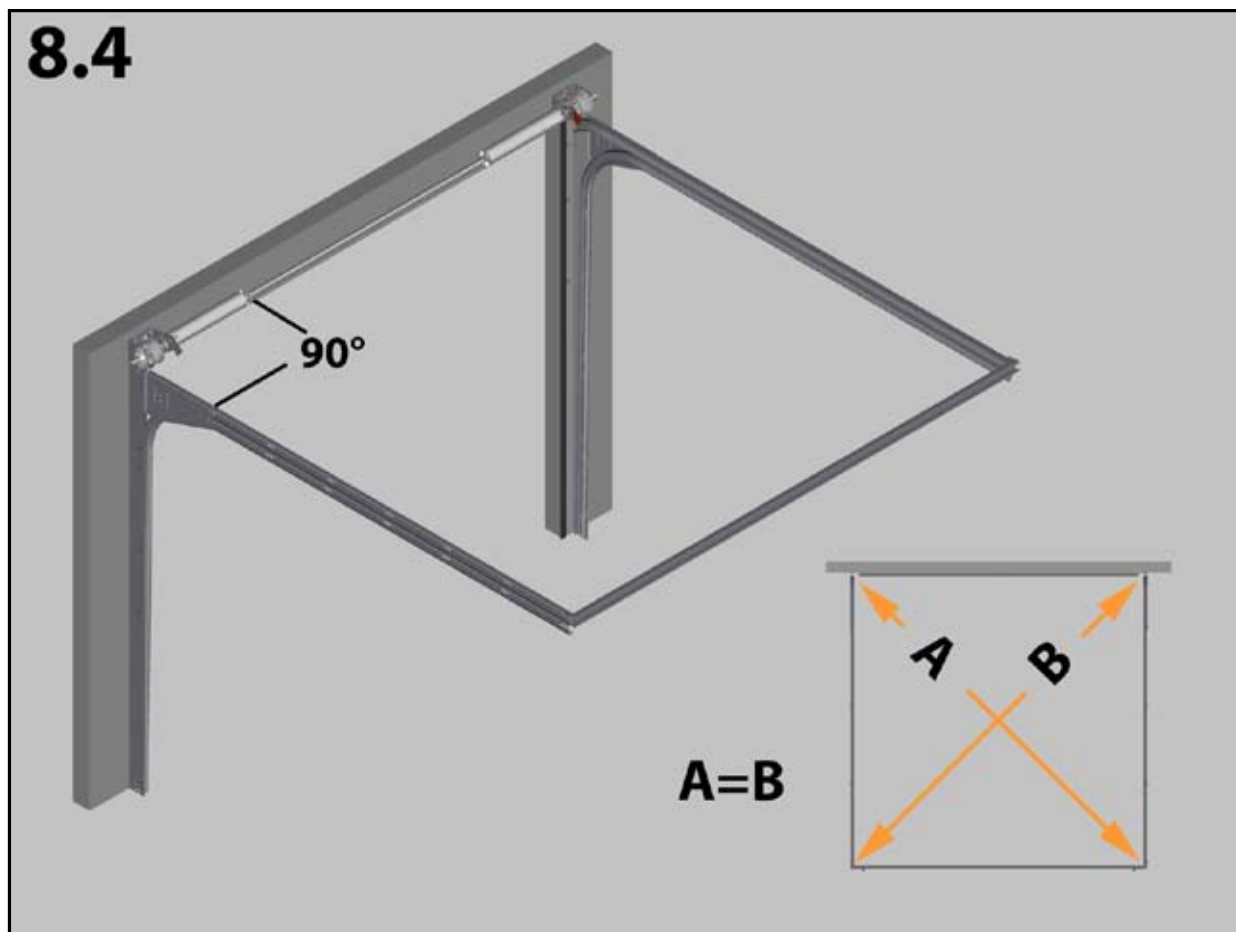

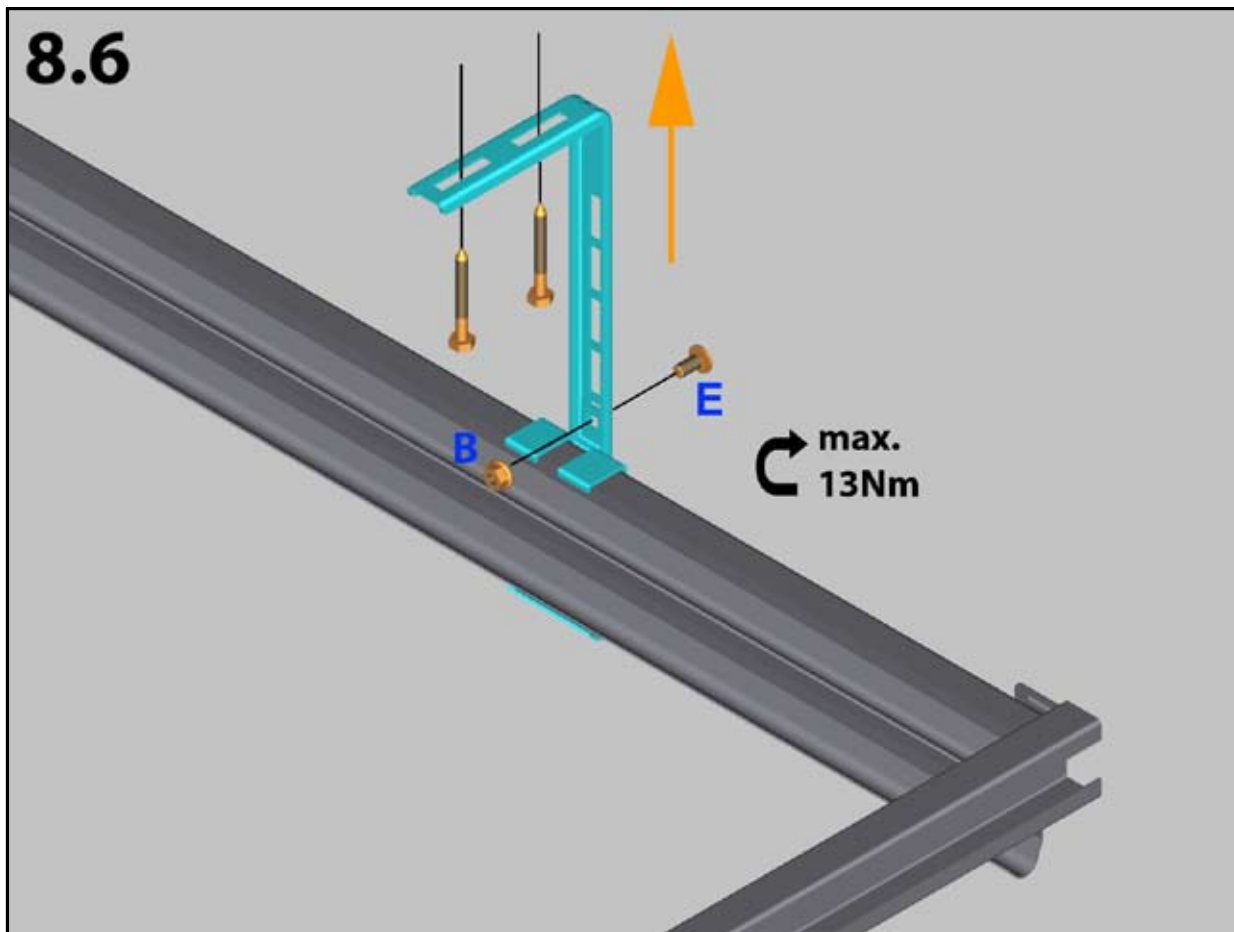
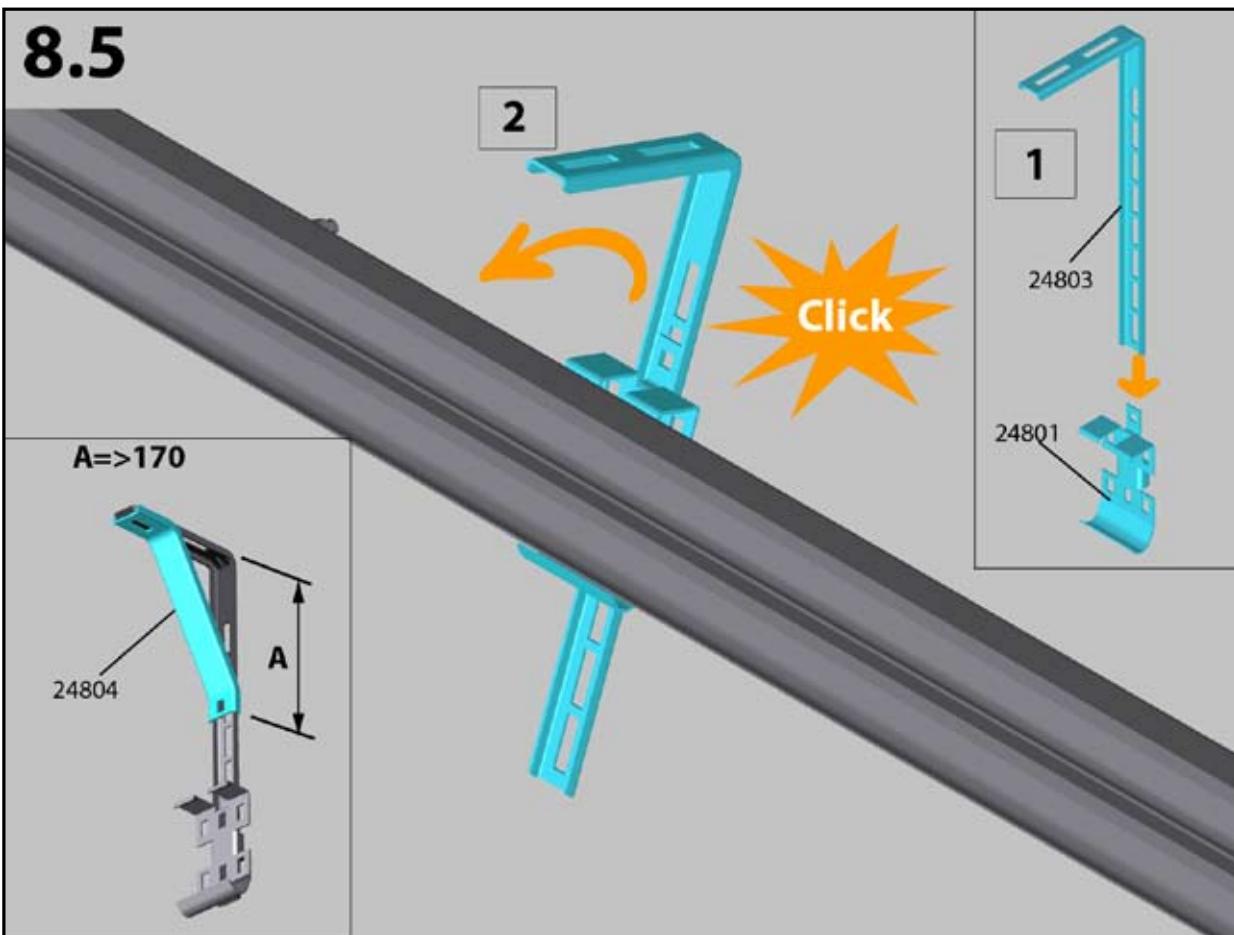

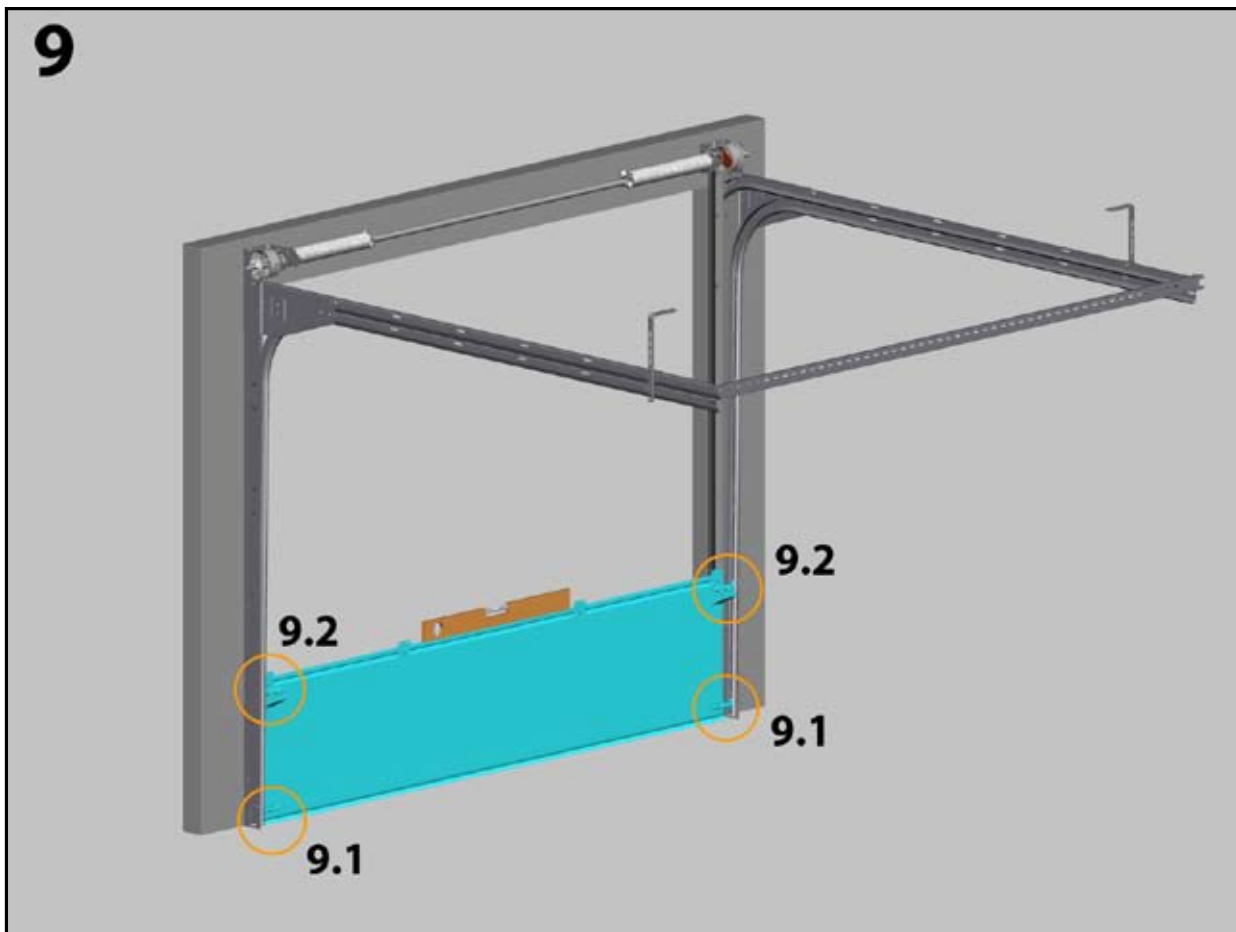
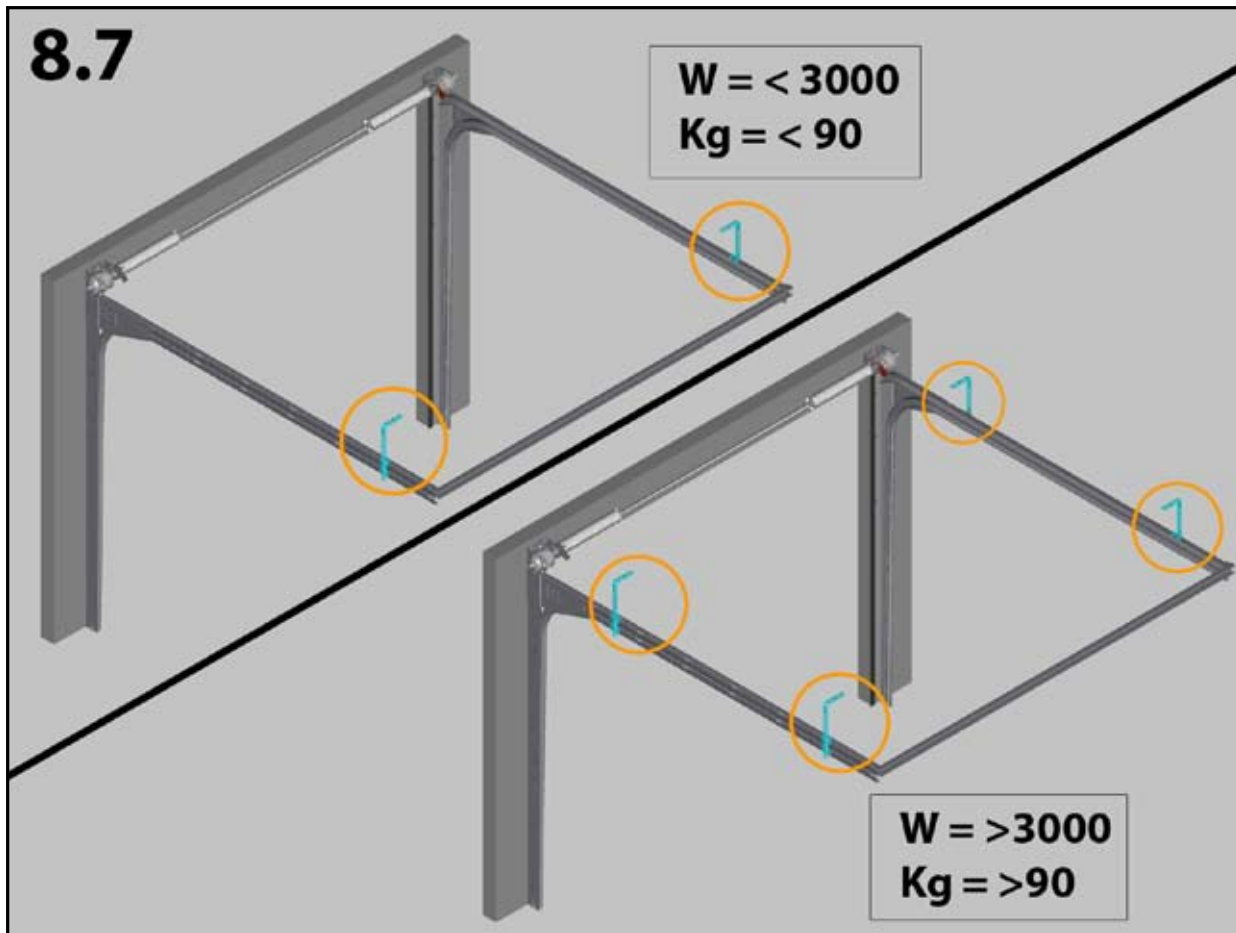

9.1a

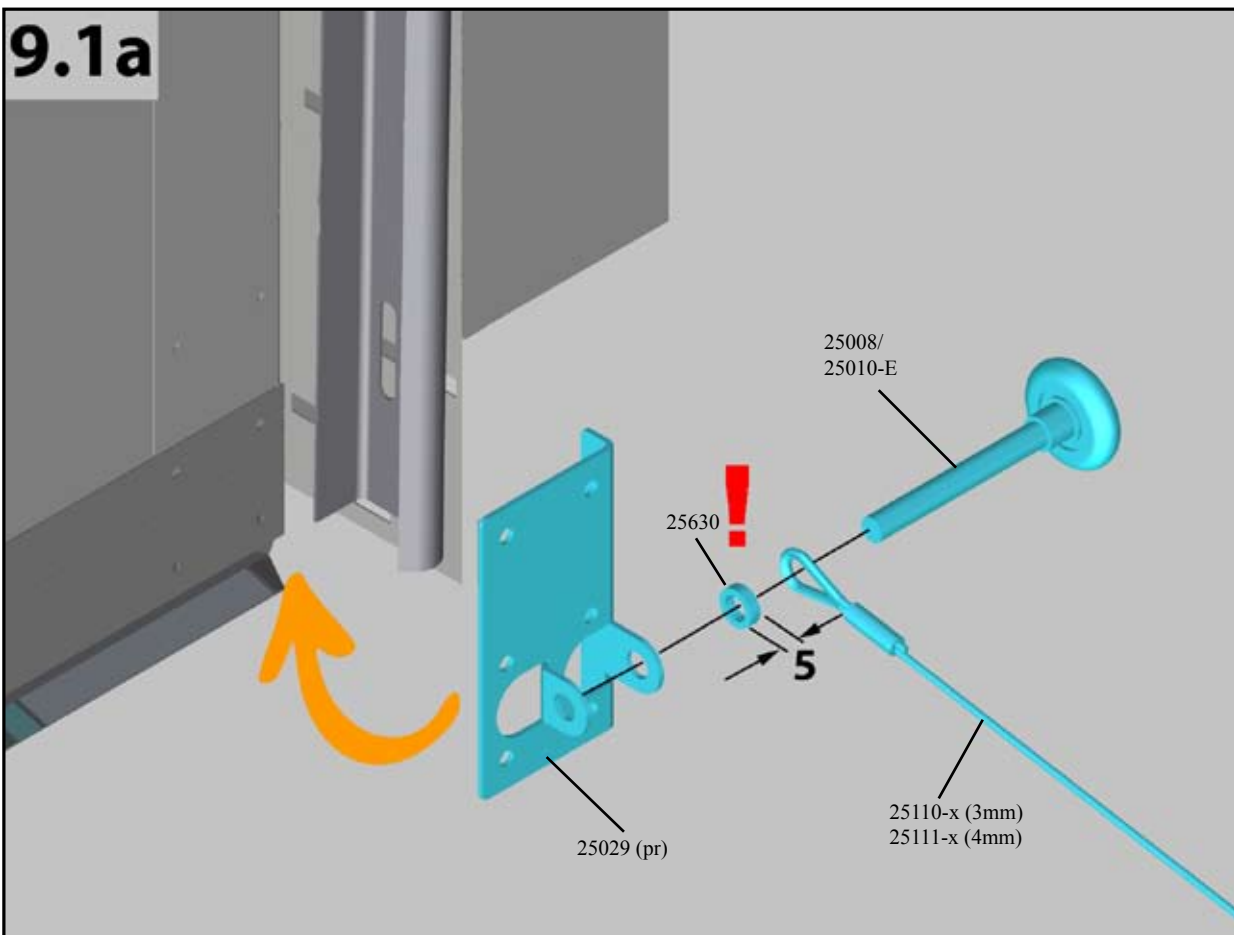

9.1b

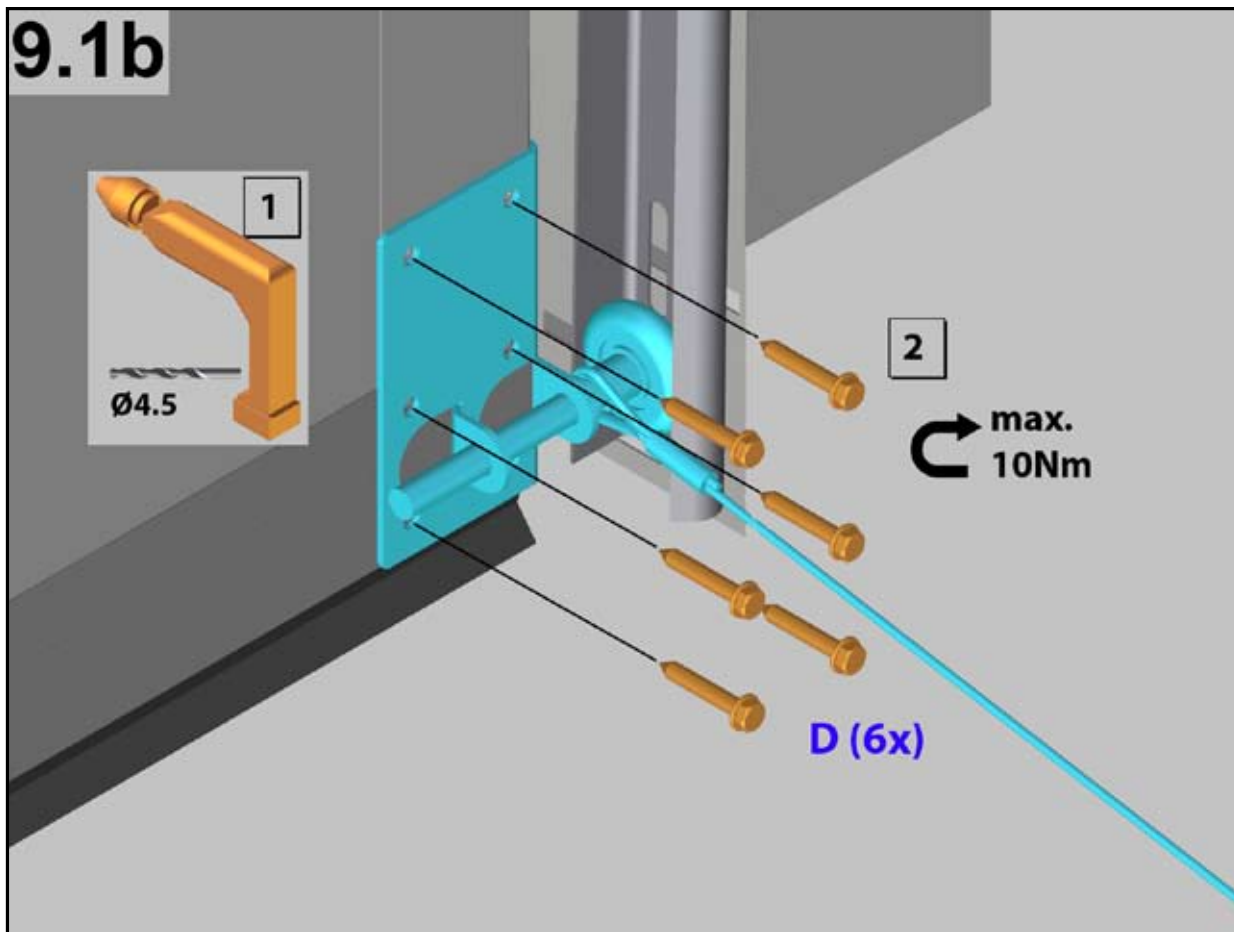

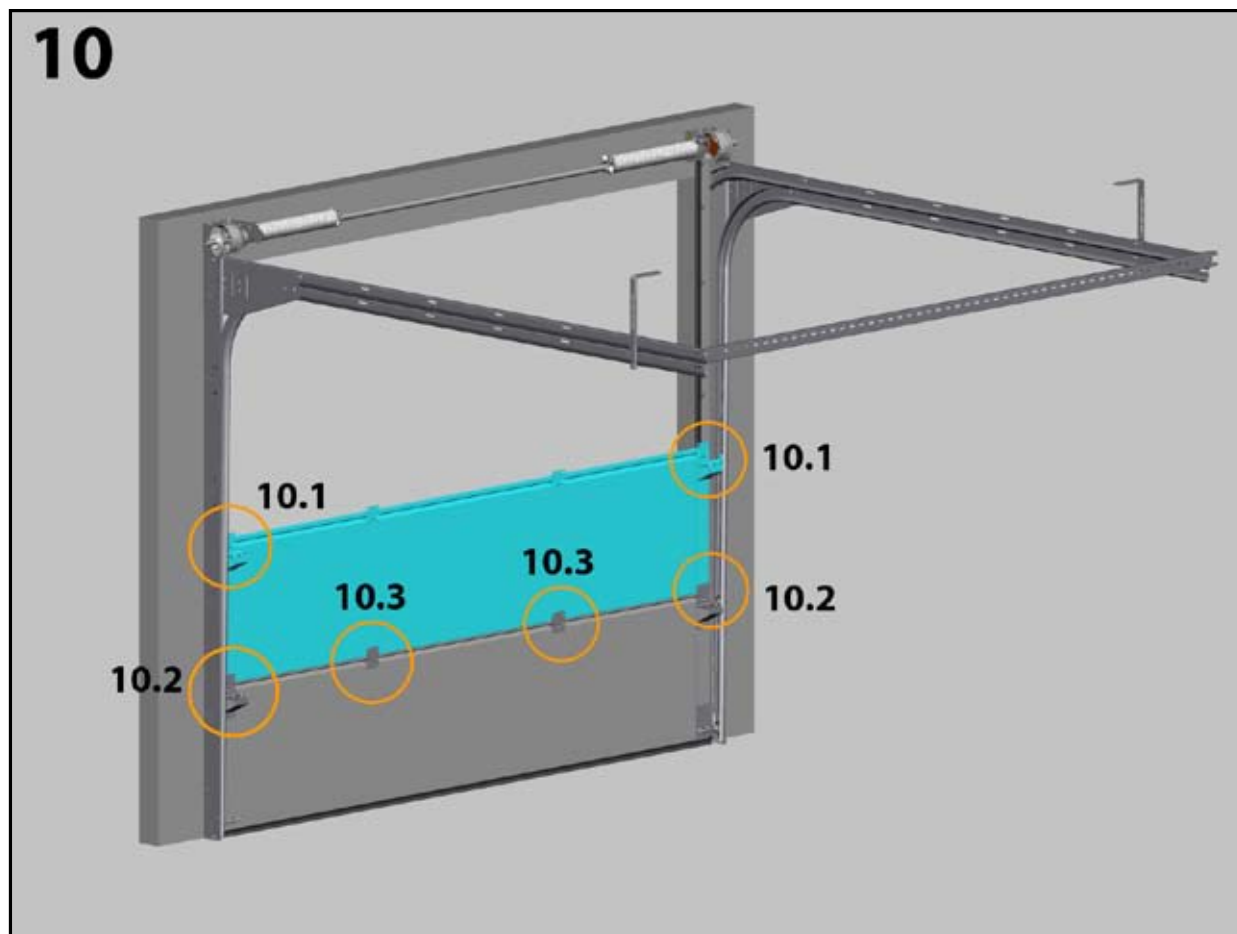
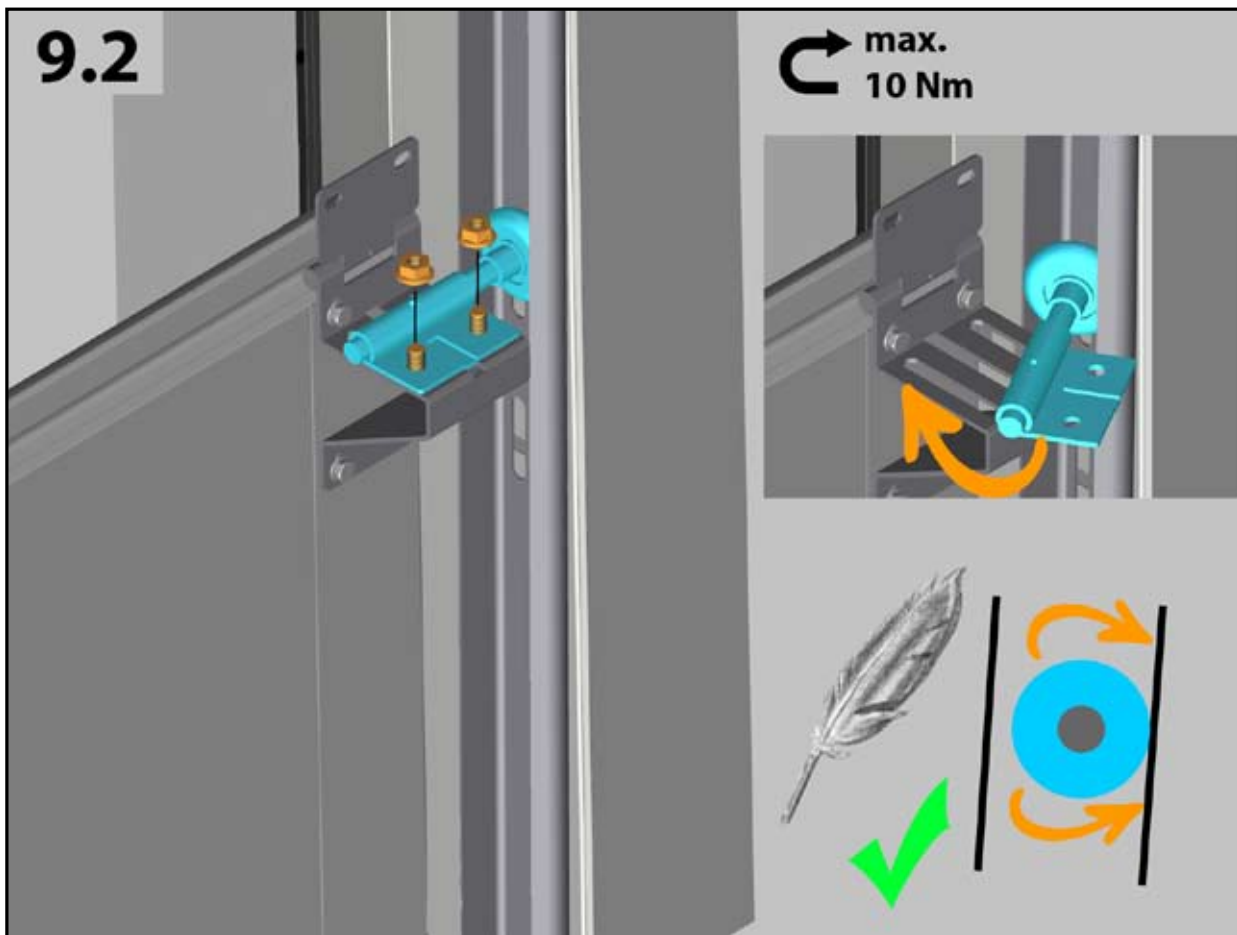

10.1

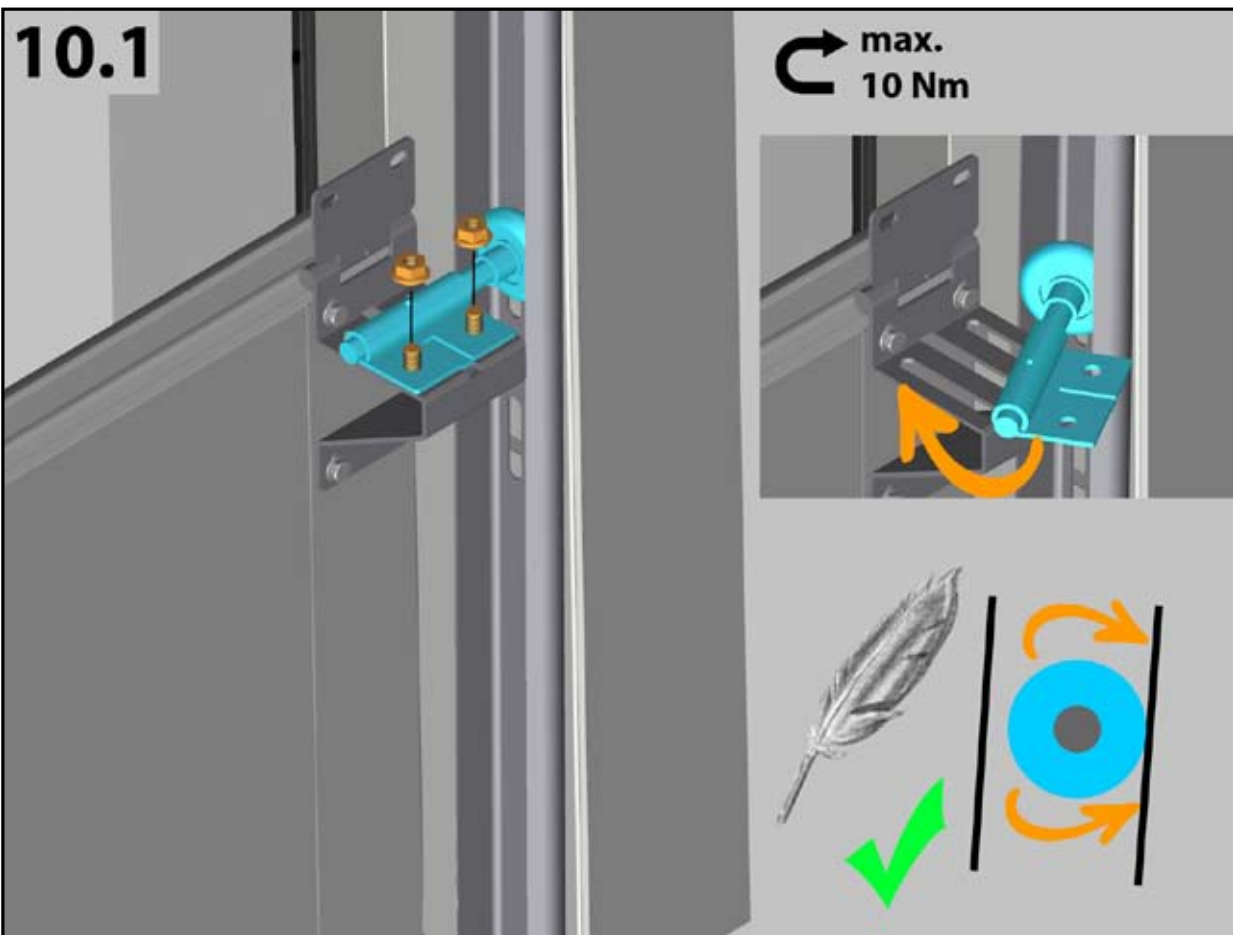

10.2

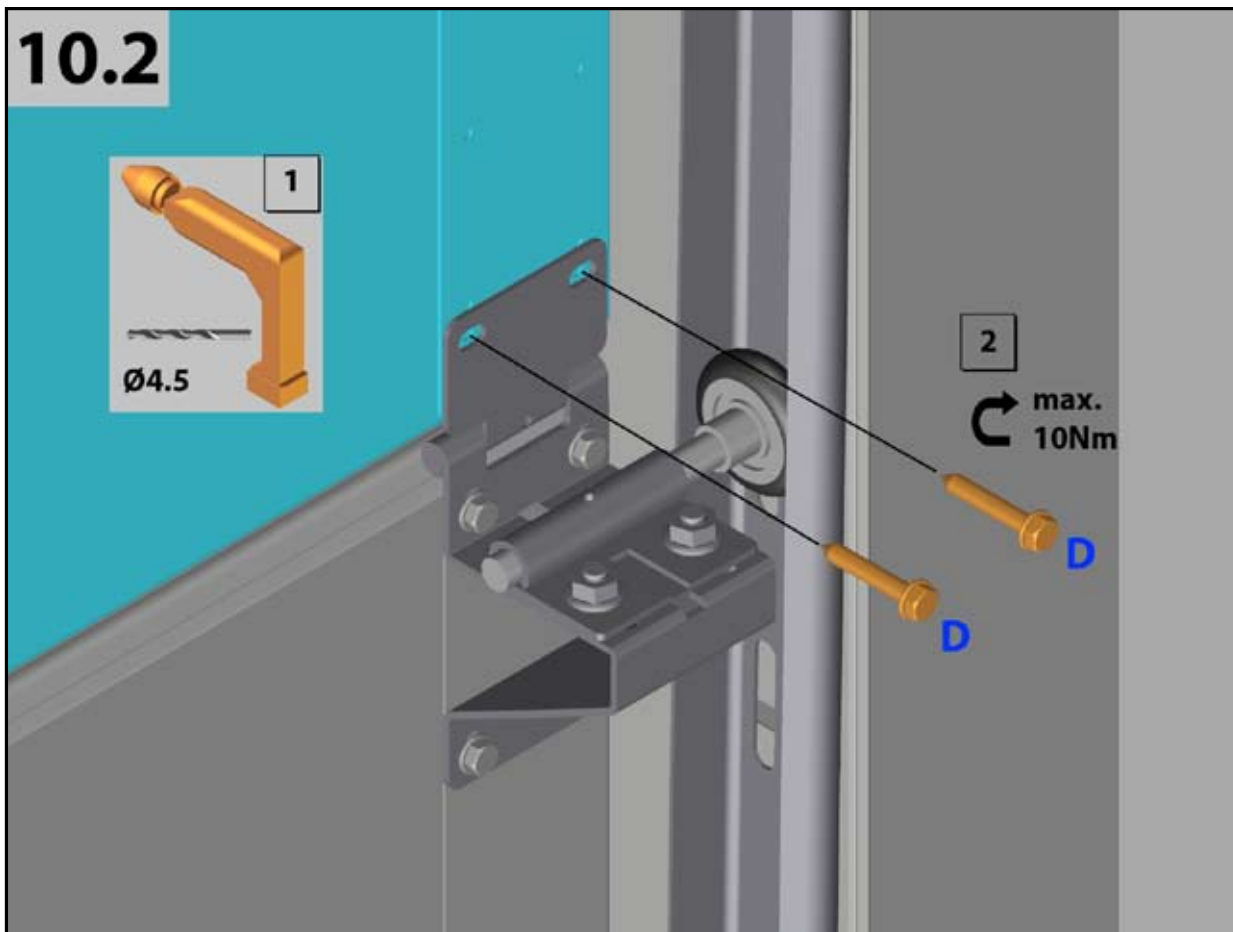

10.3

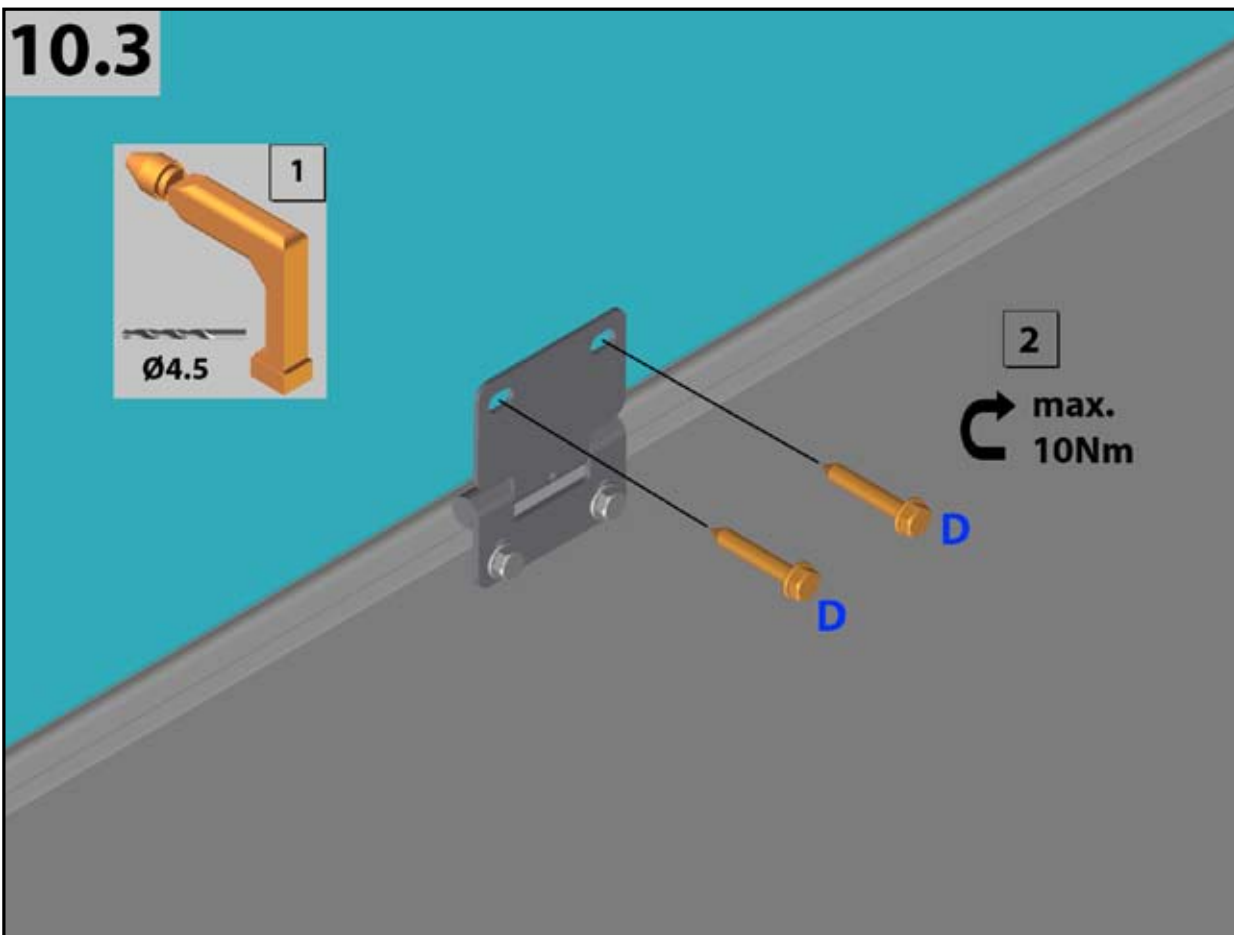

11

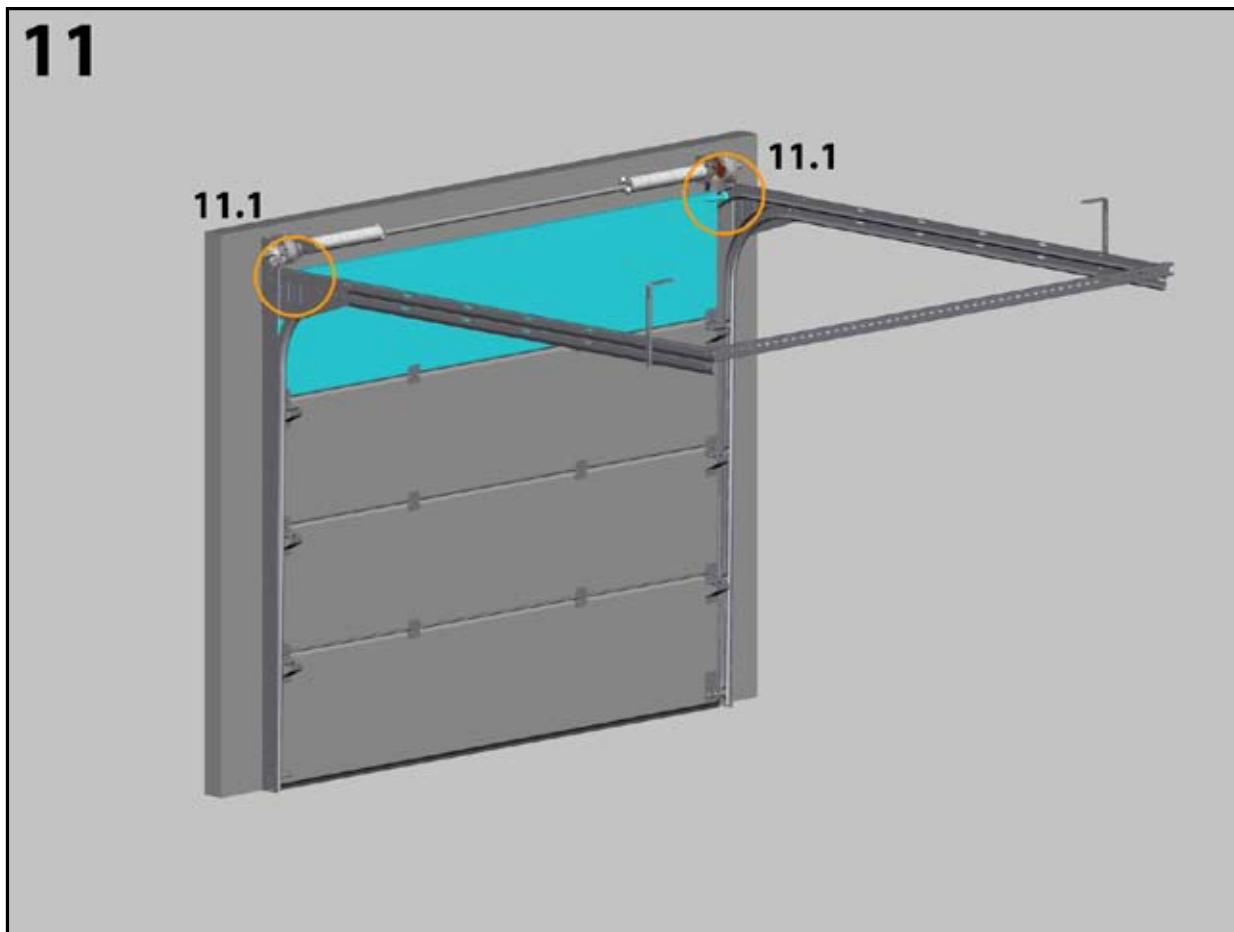

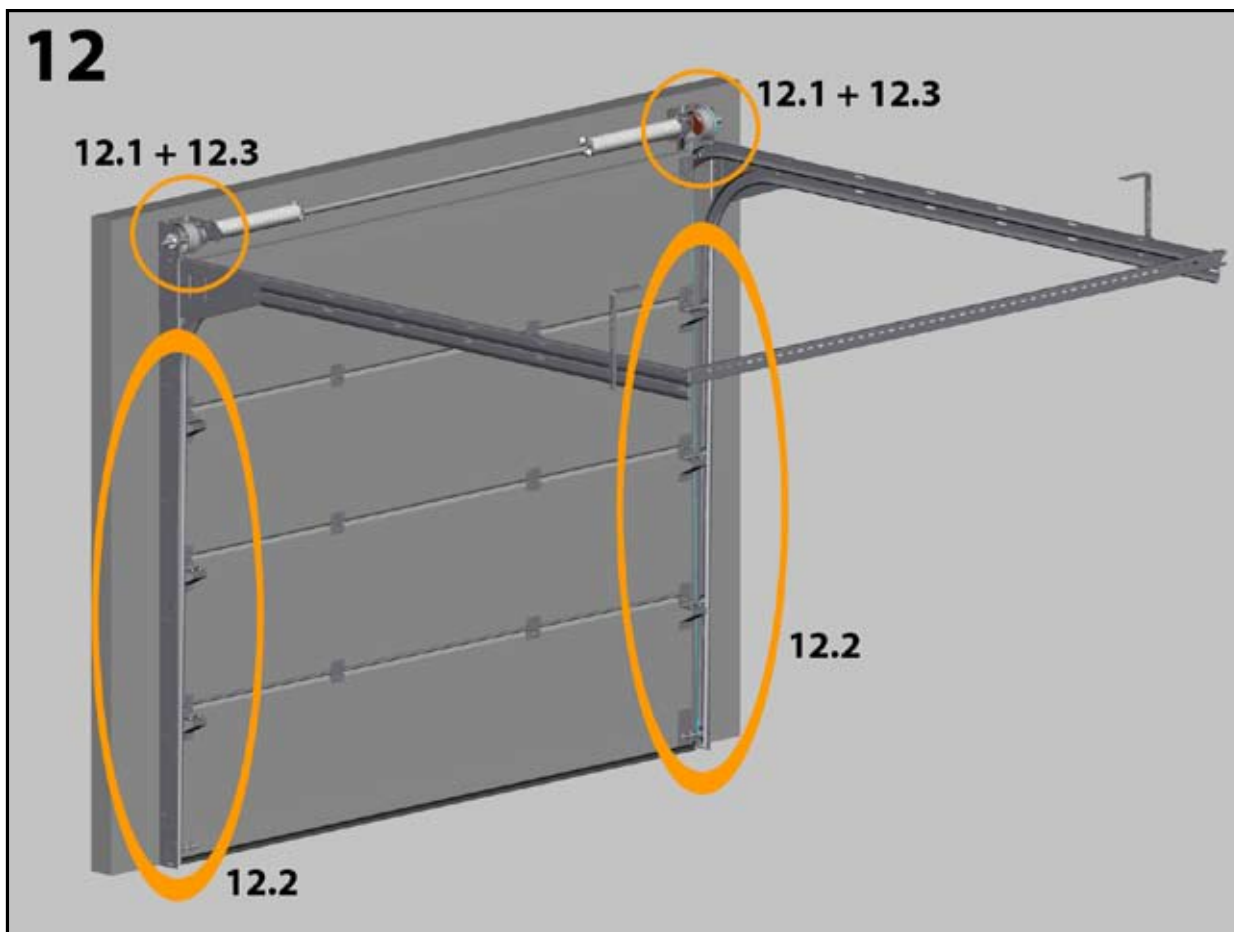
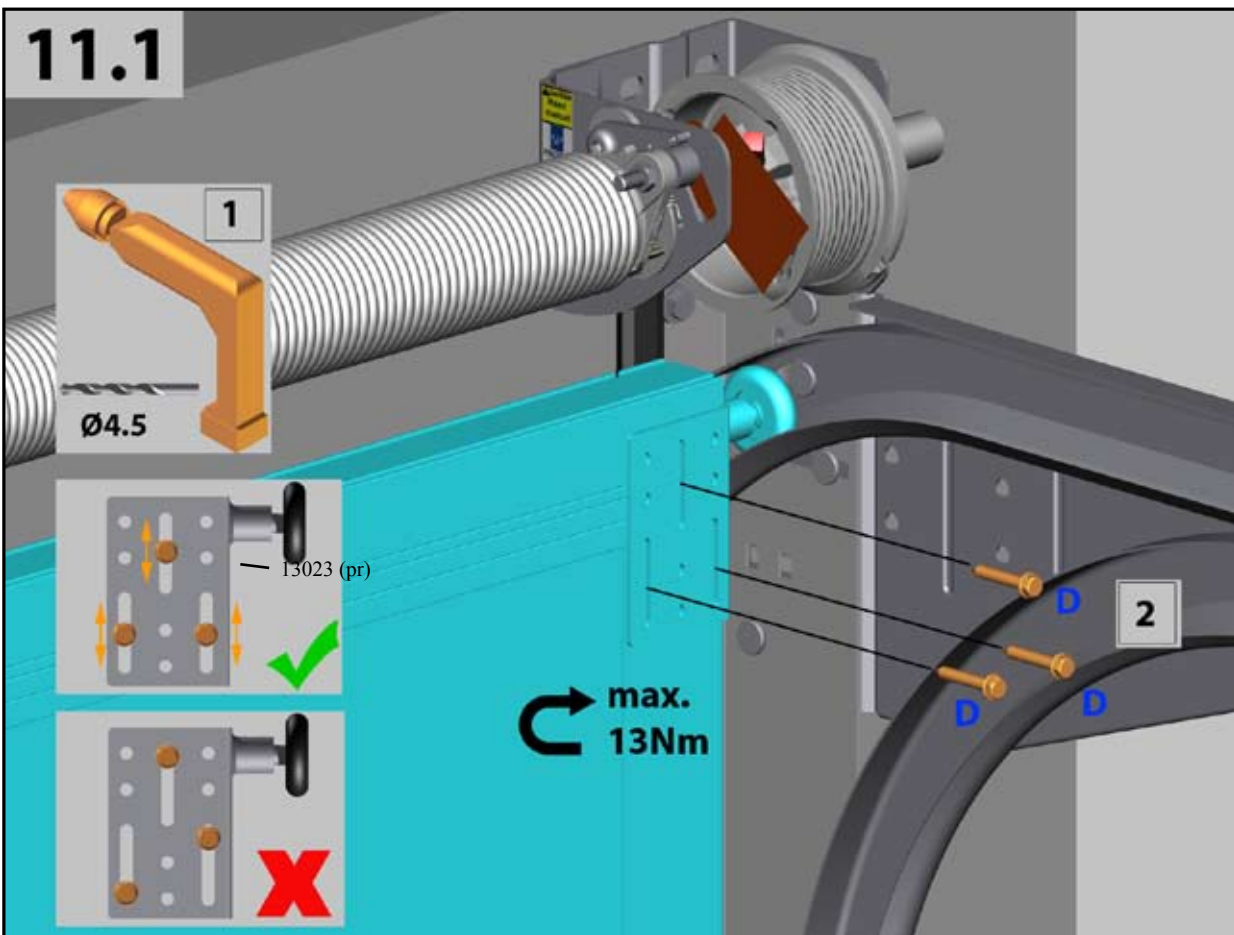

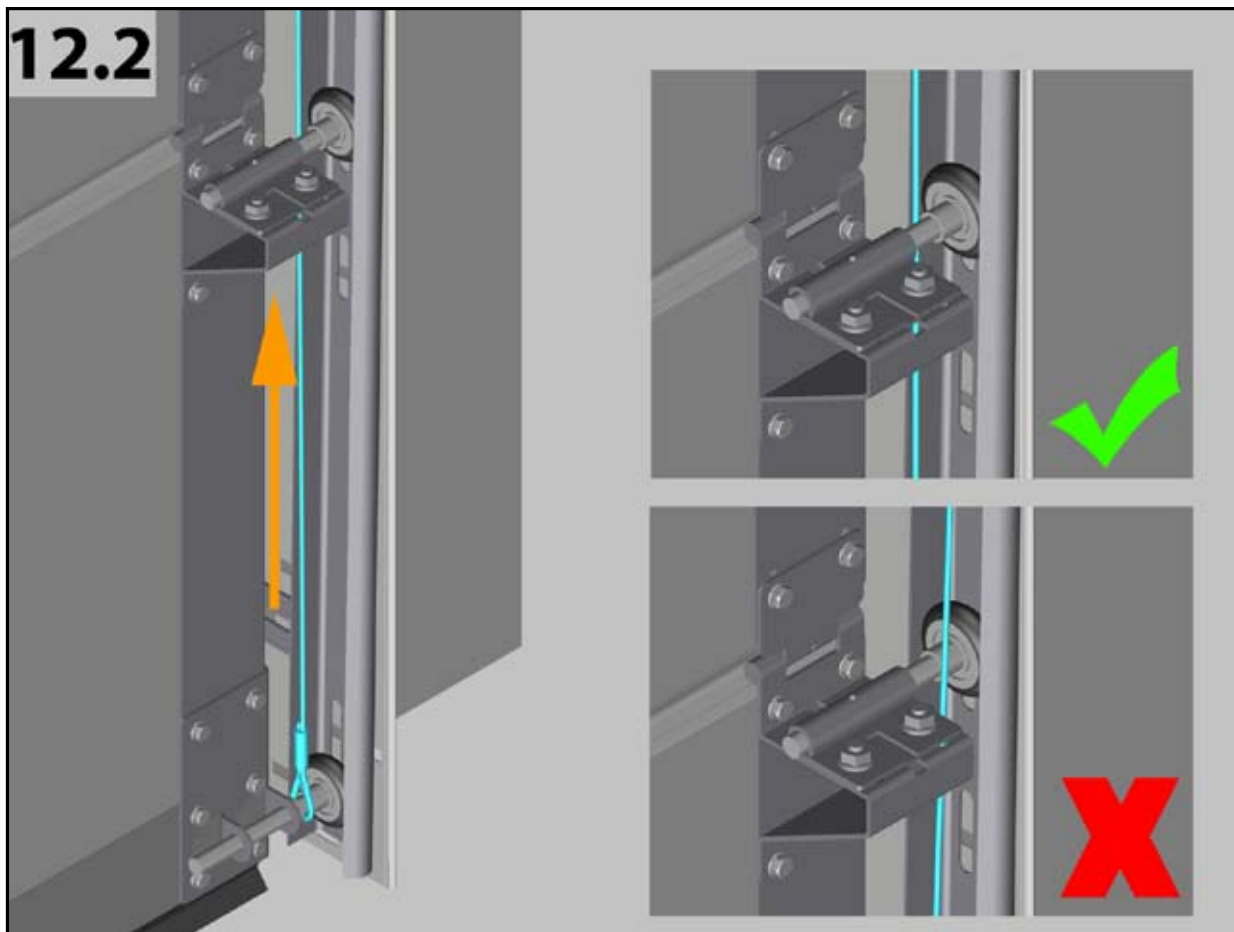
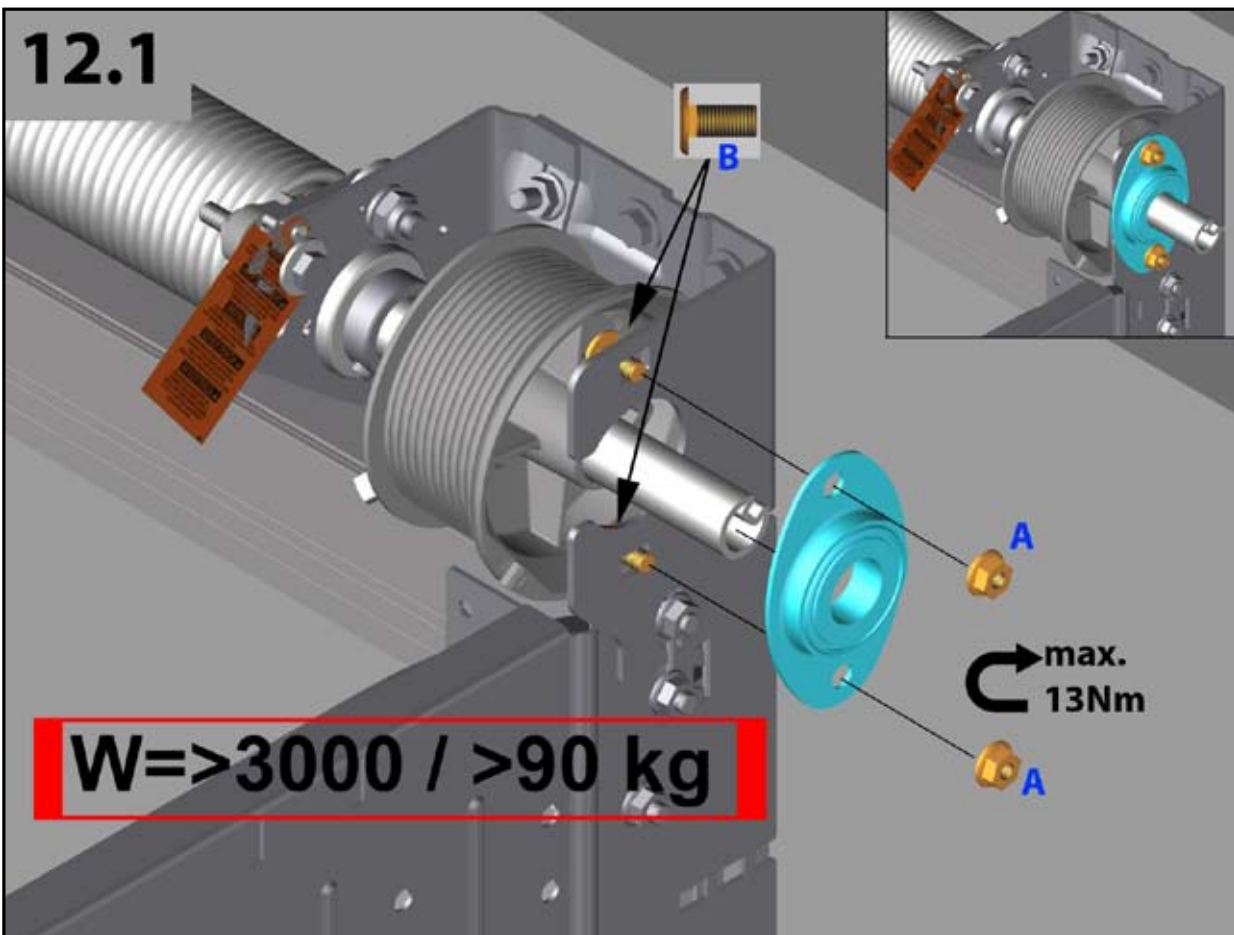

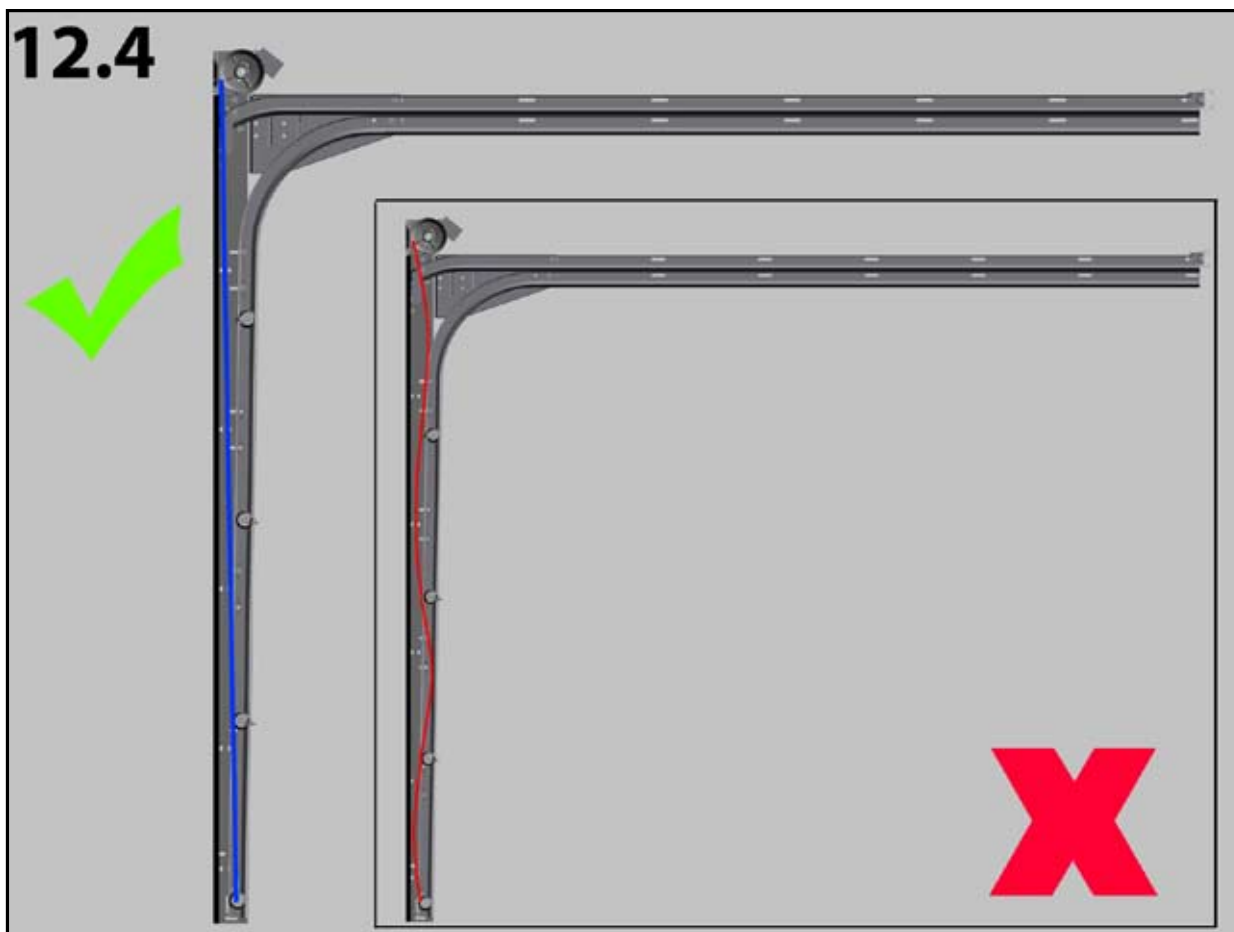
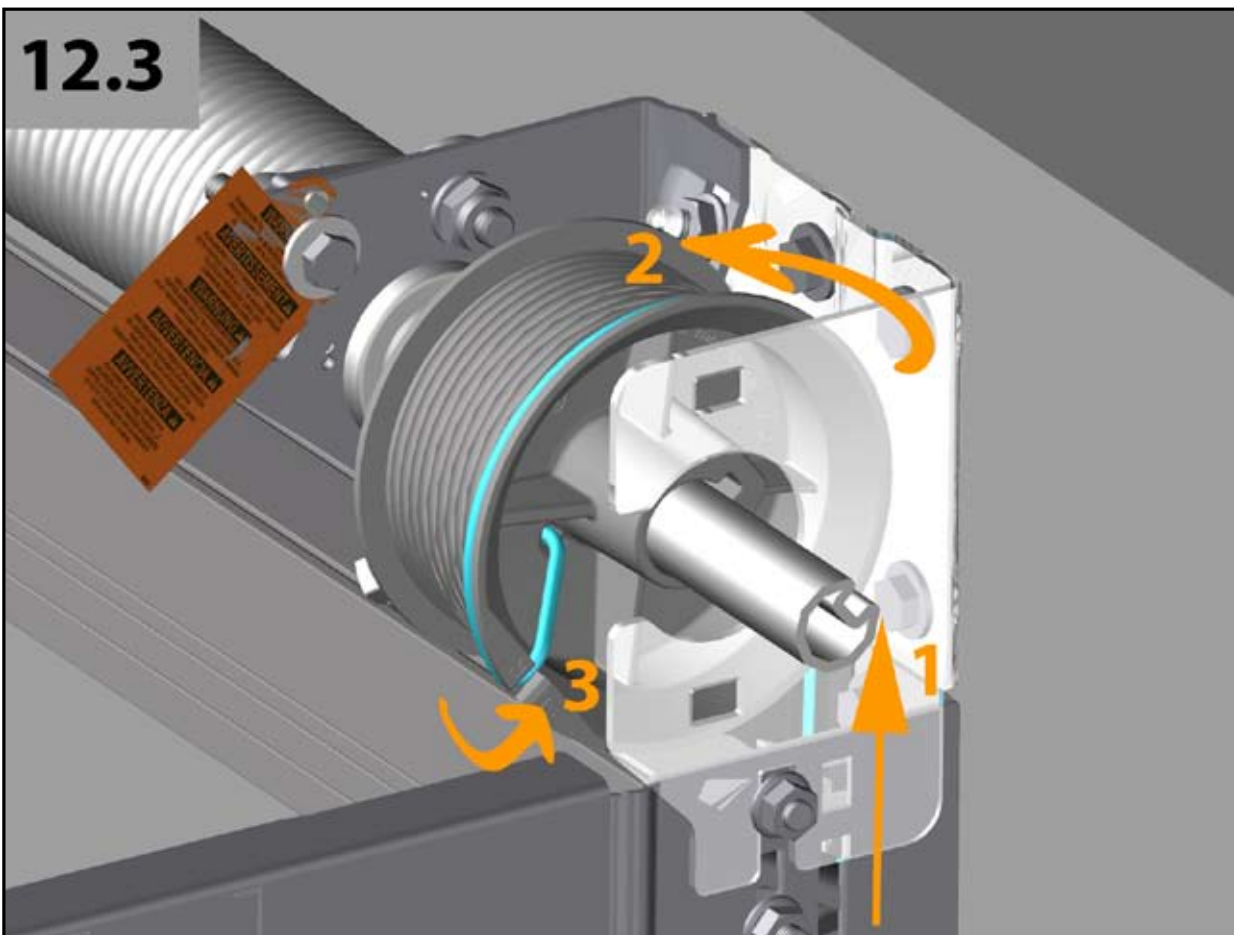

12.5

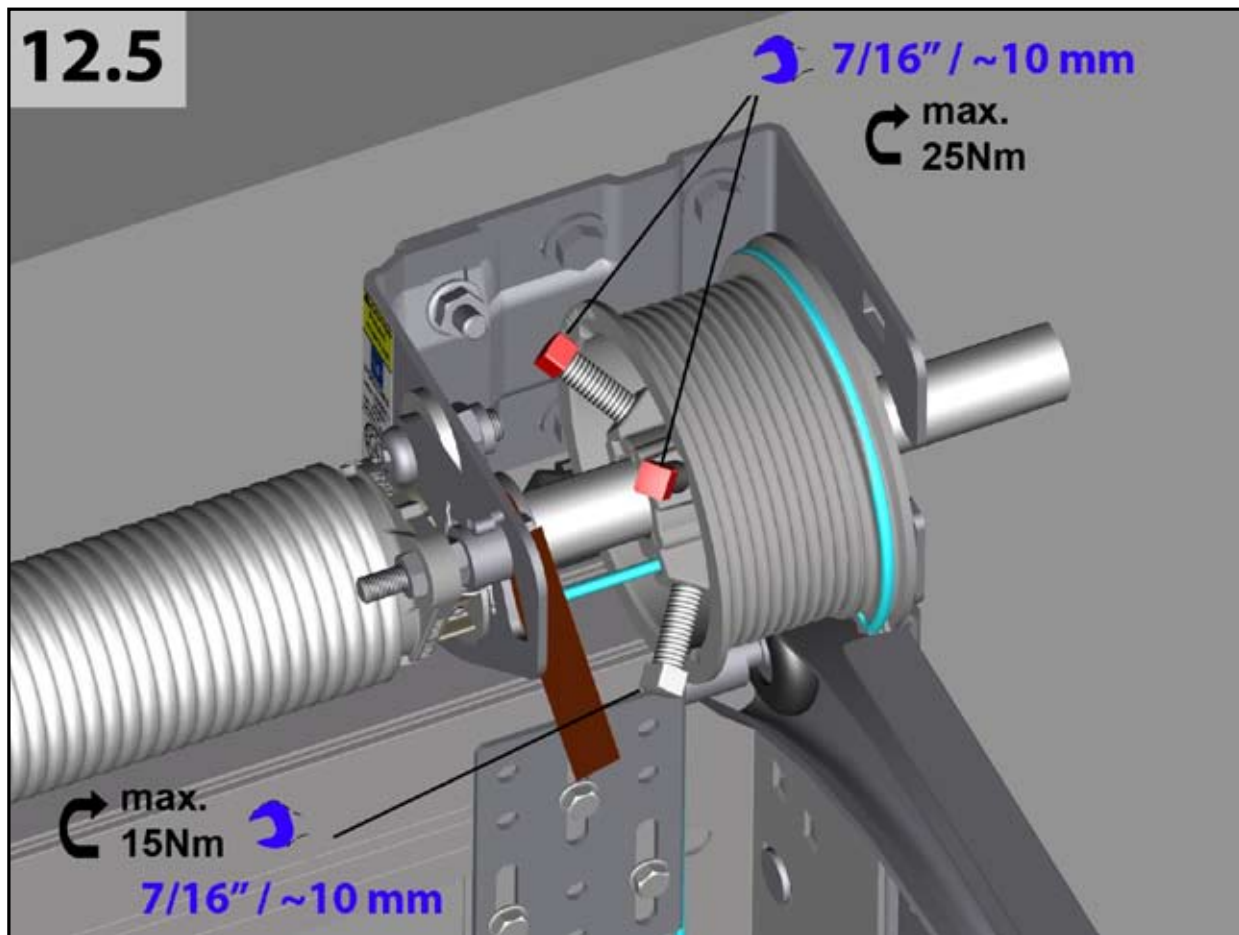

13

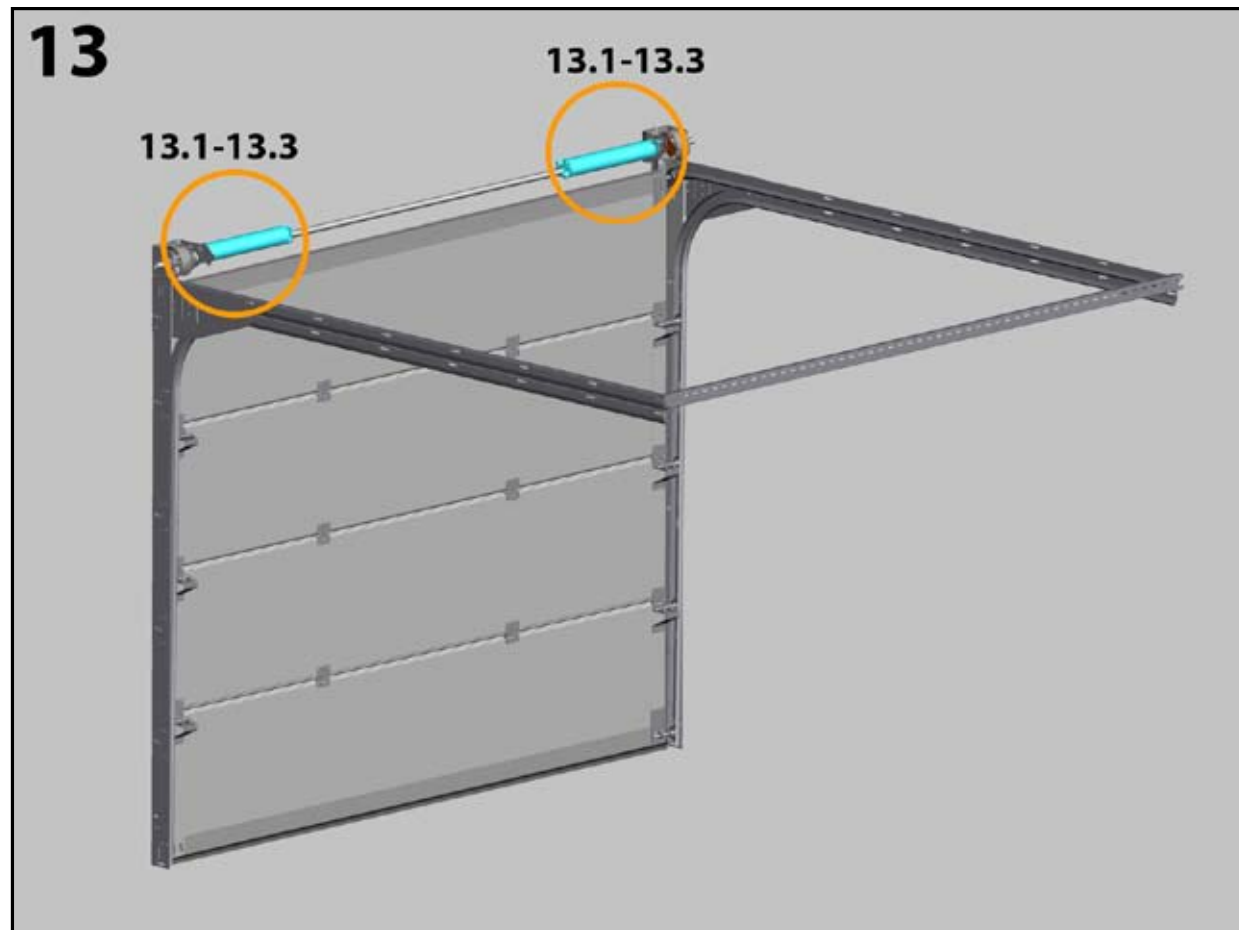

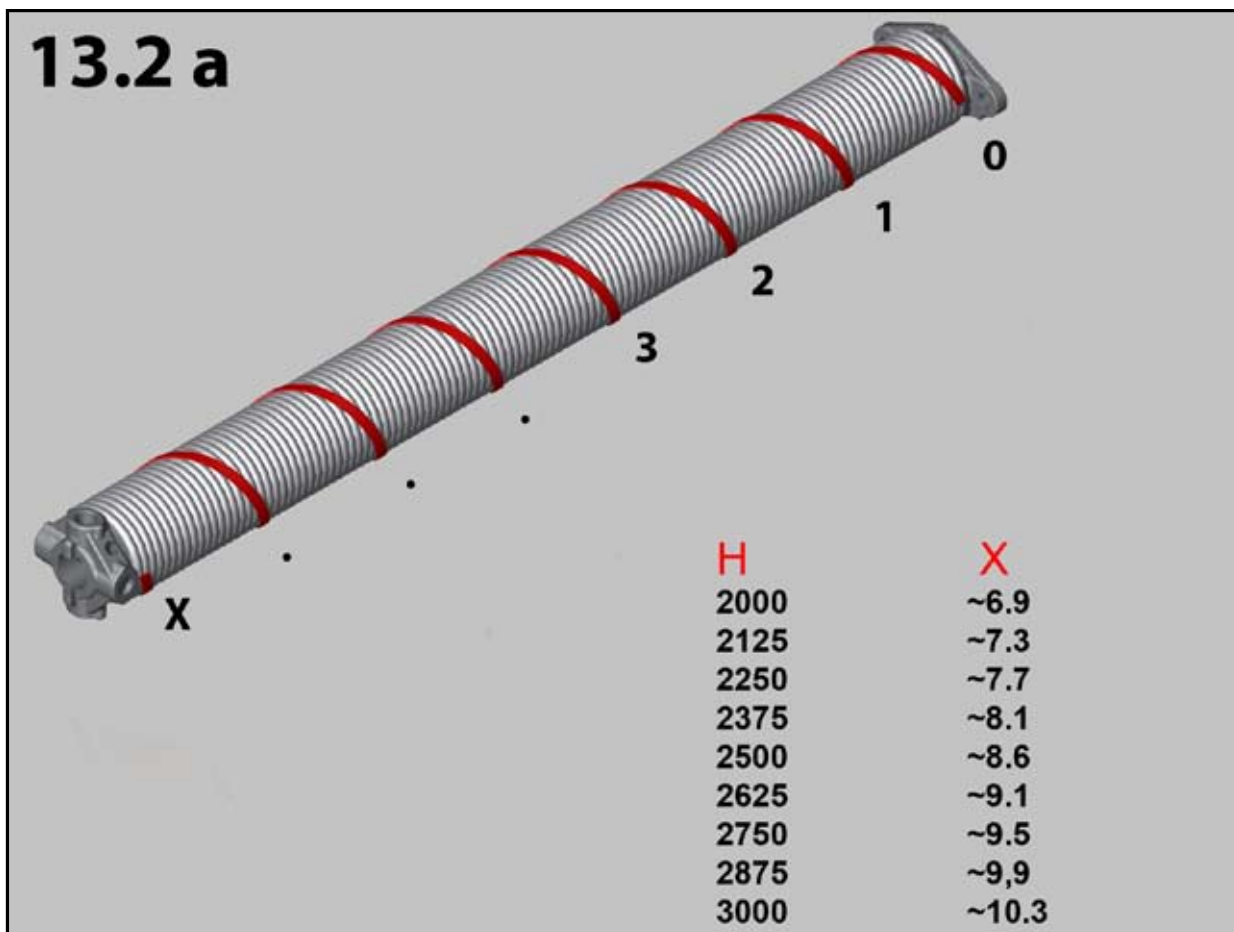
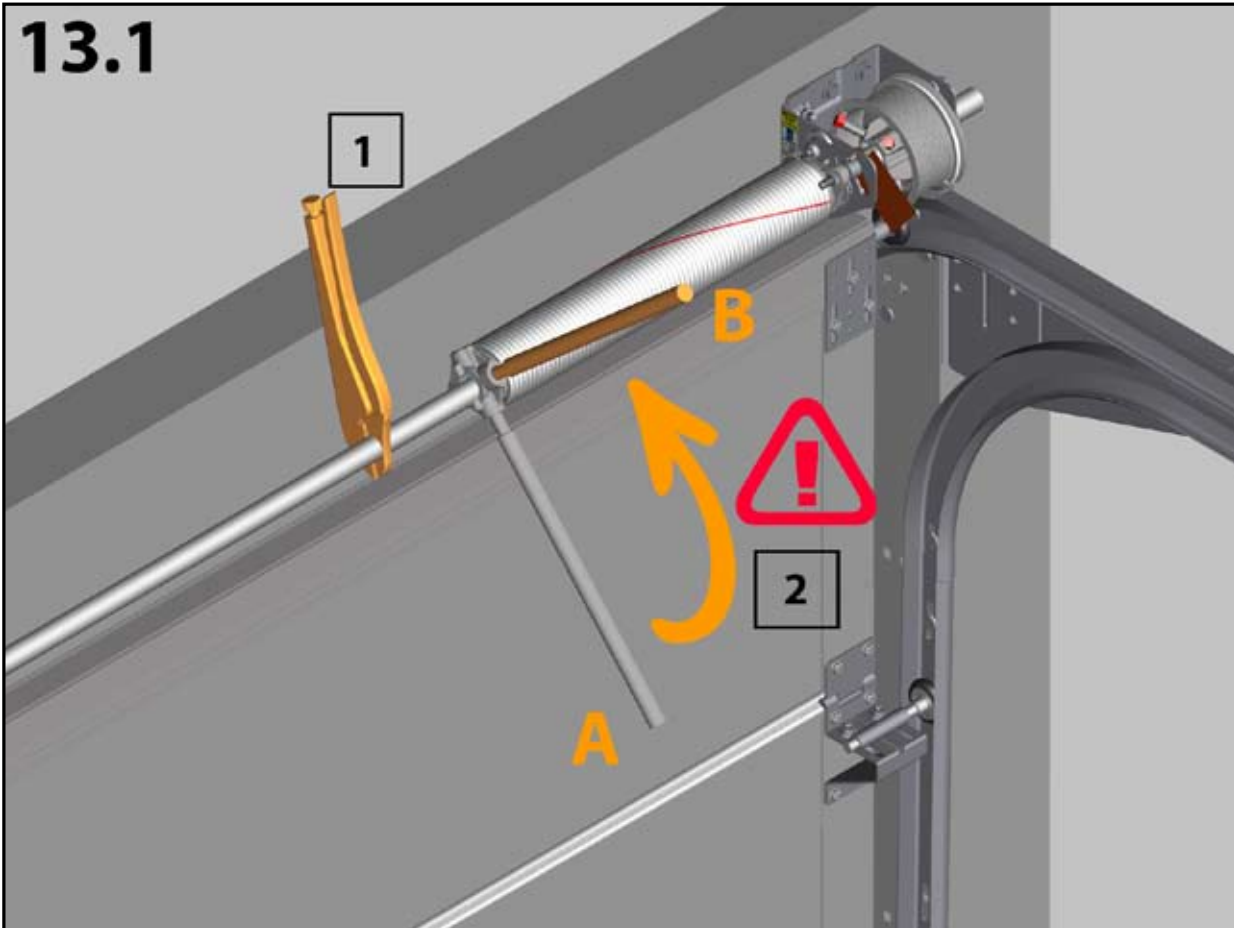

13.2 b

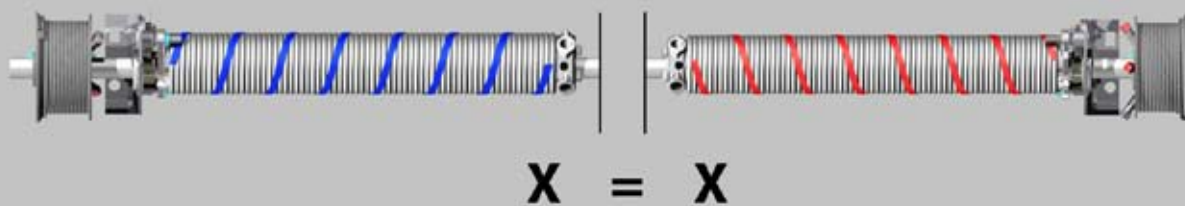

13.3

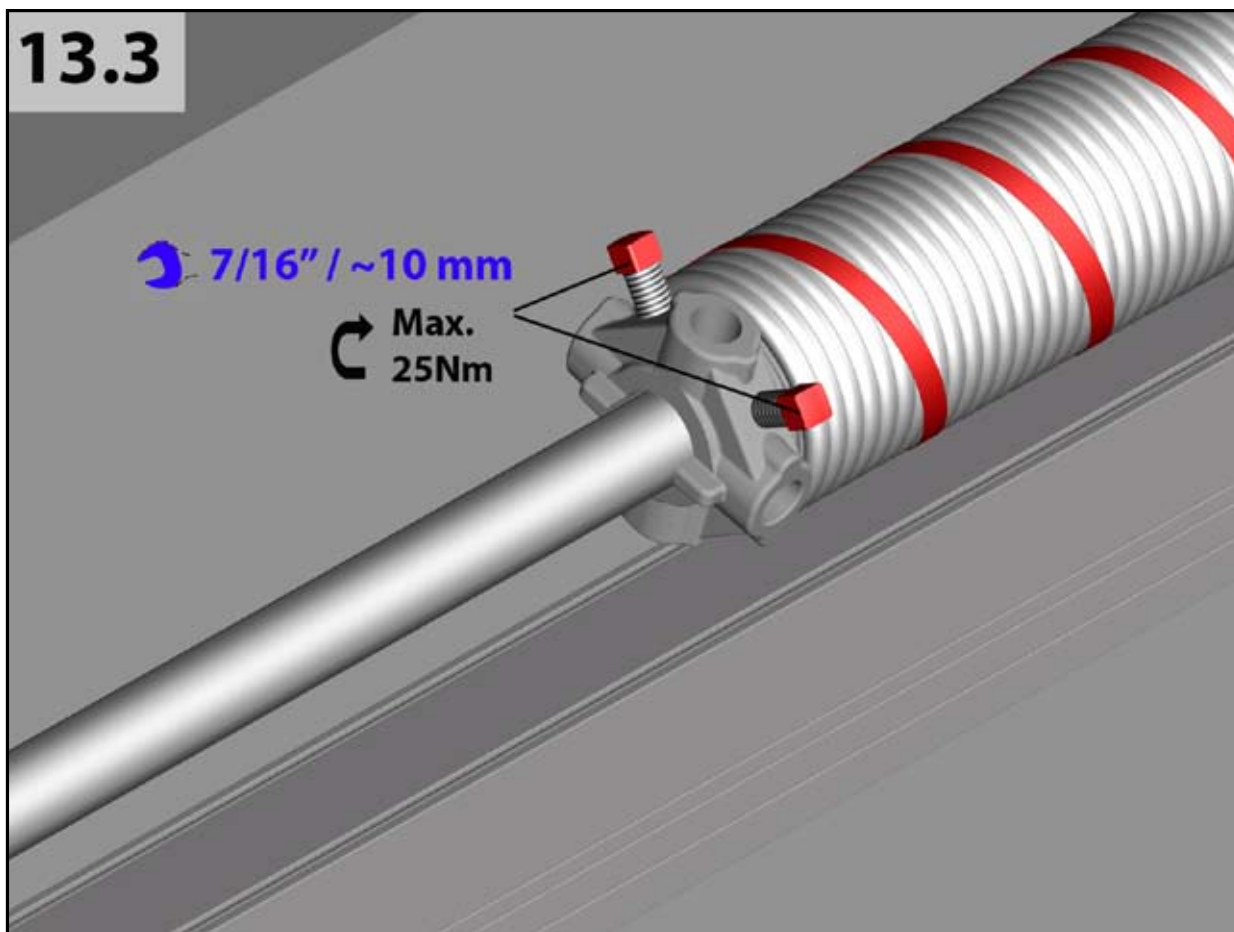

13.4

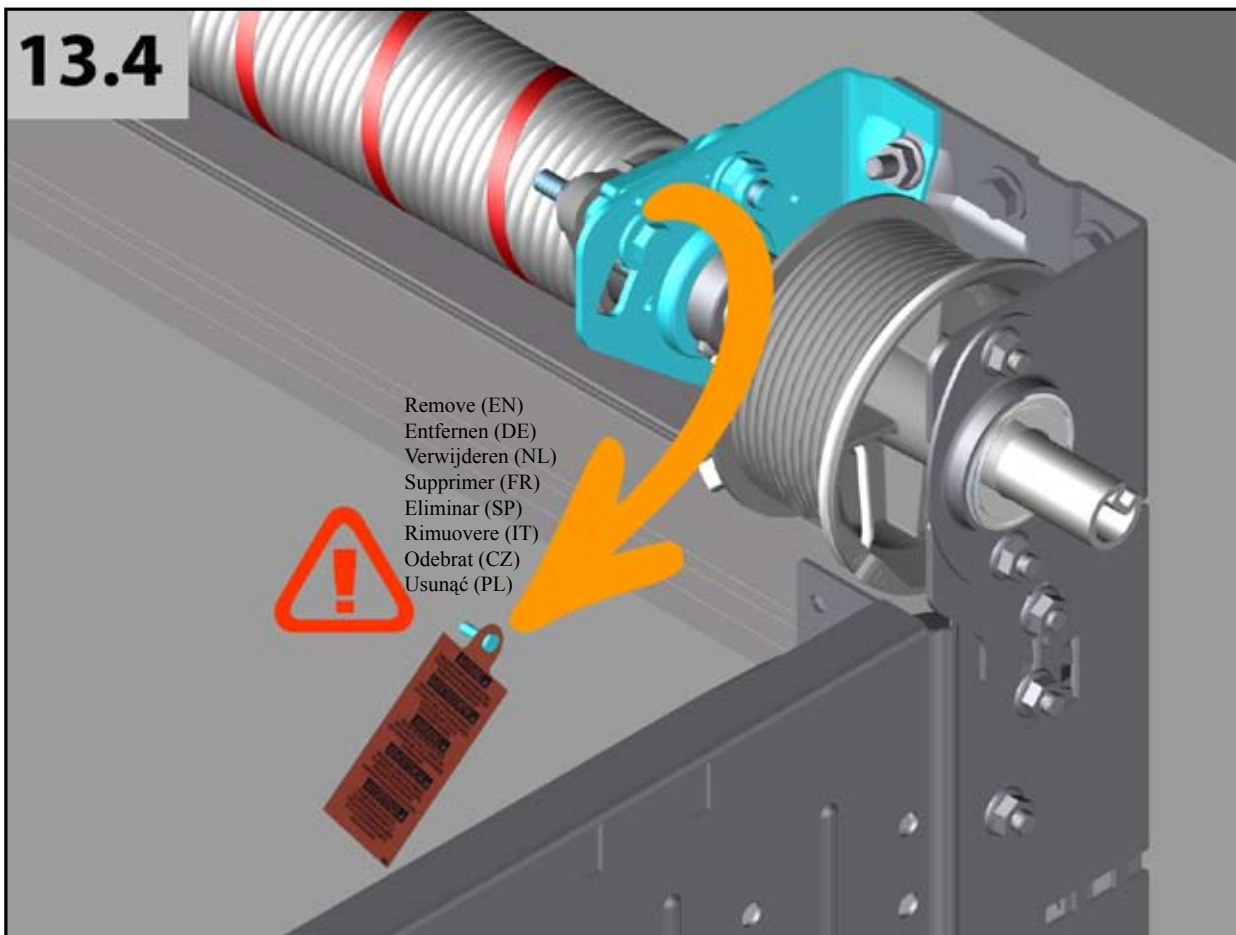

14

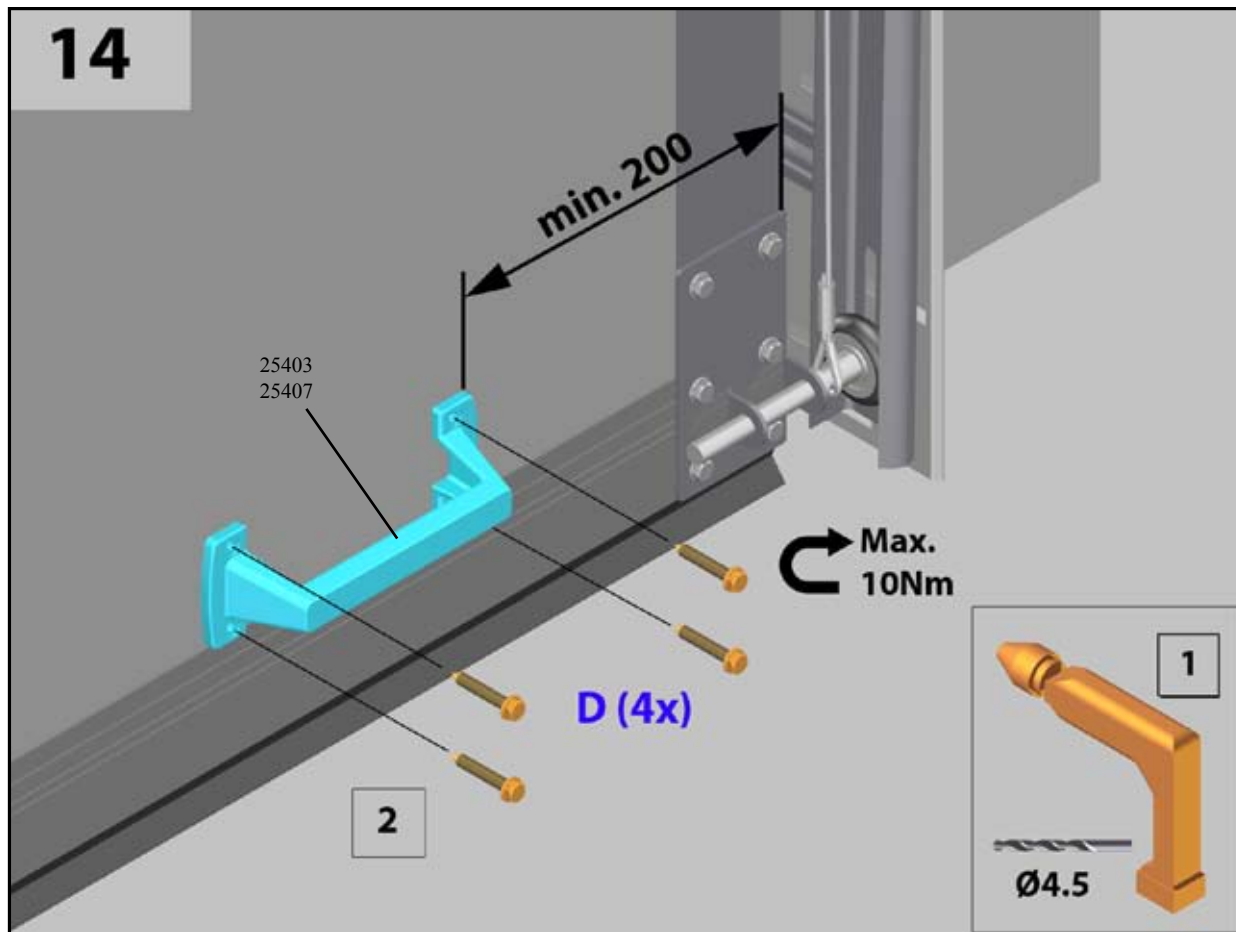

14.1

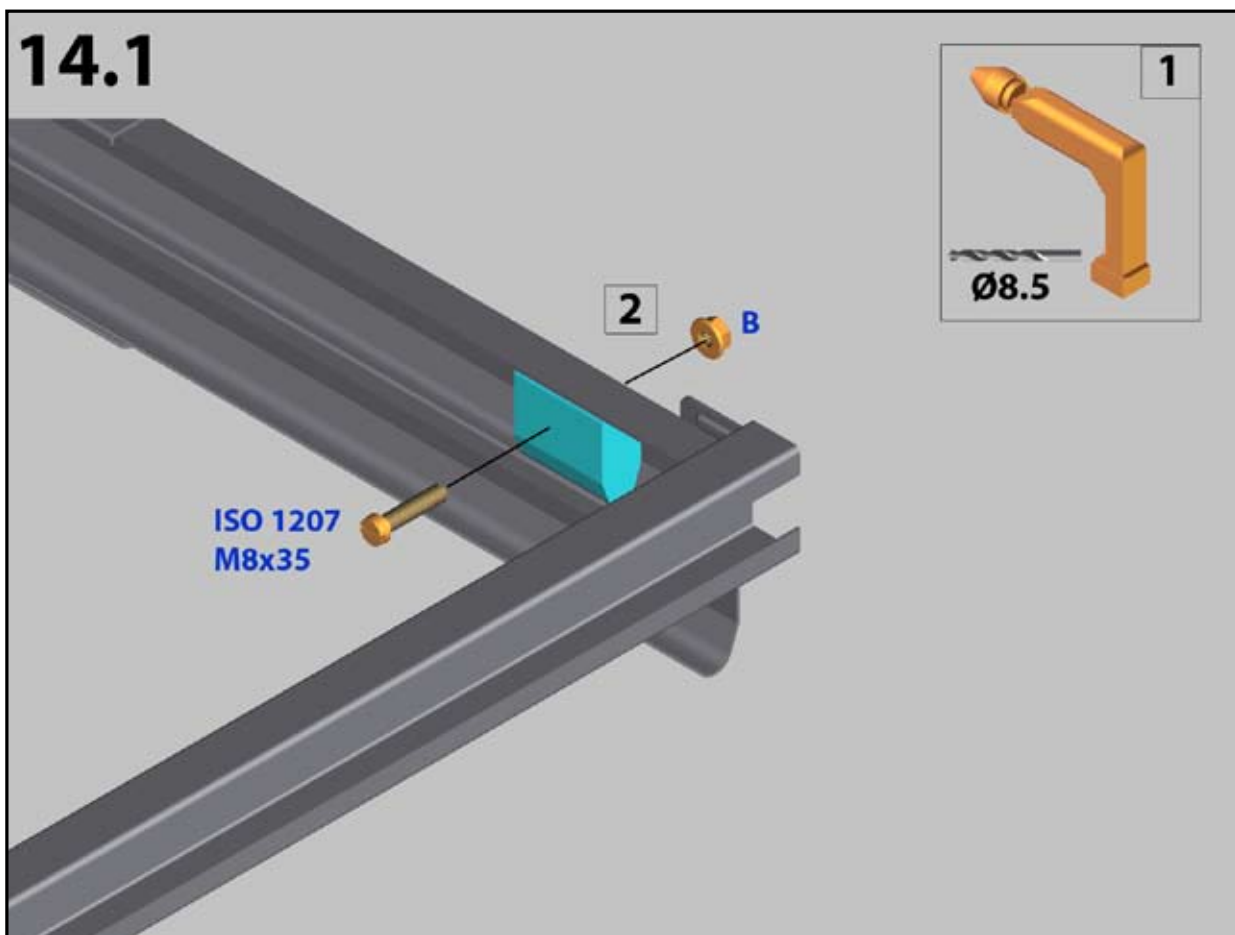

15

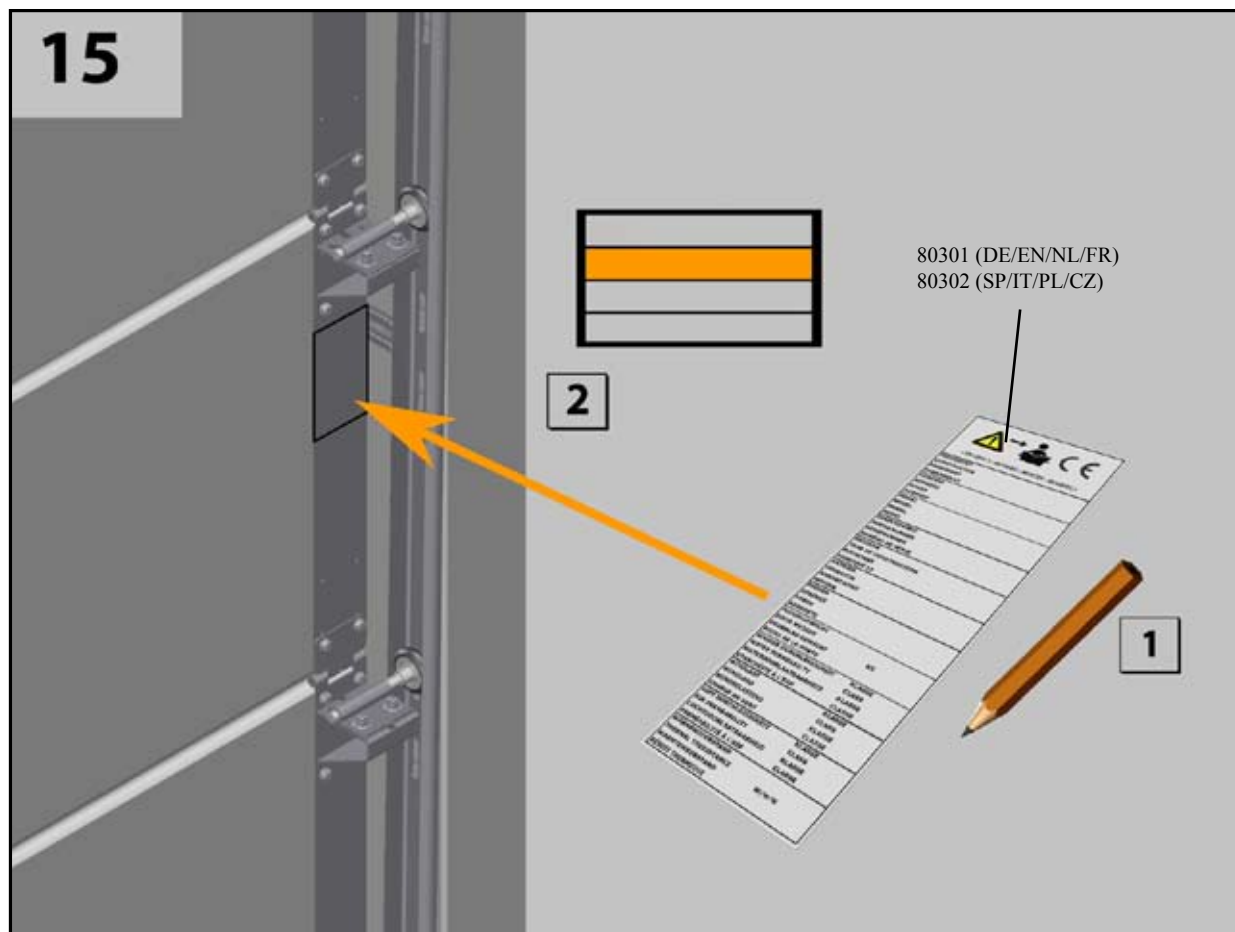

16

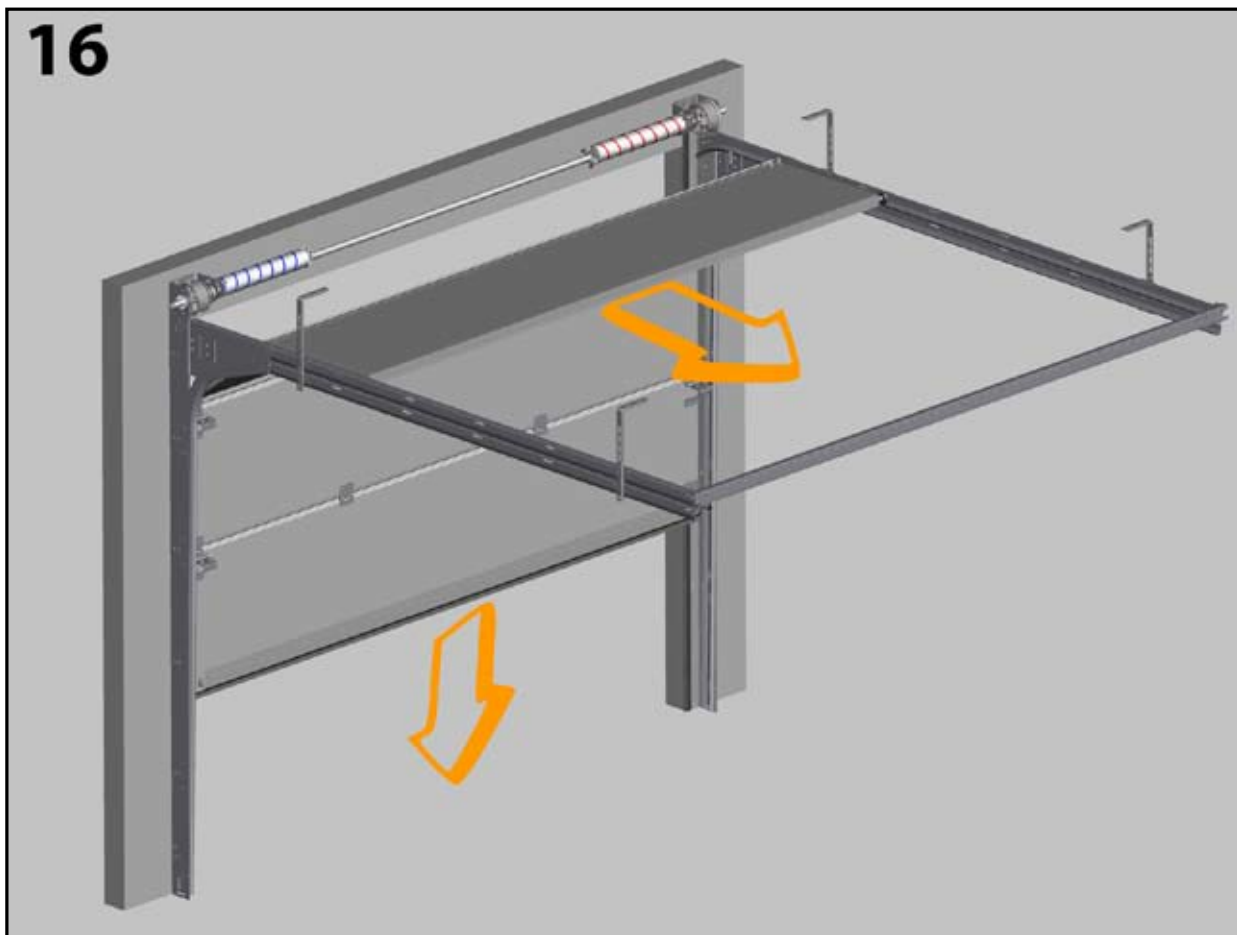

17

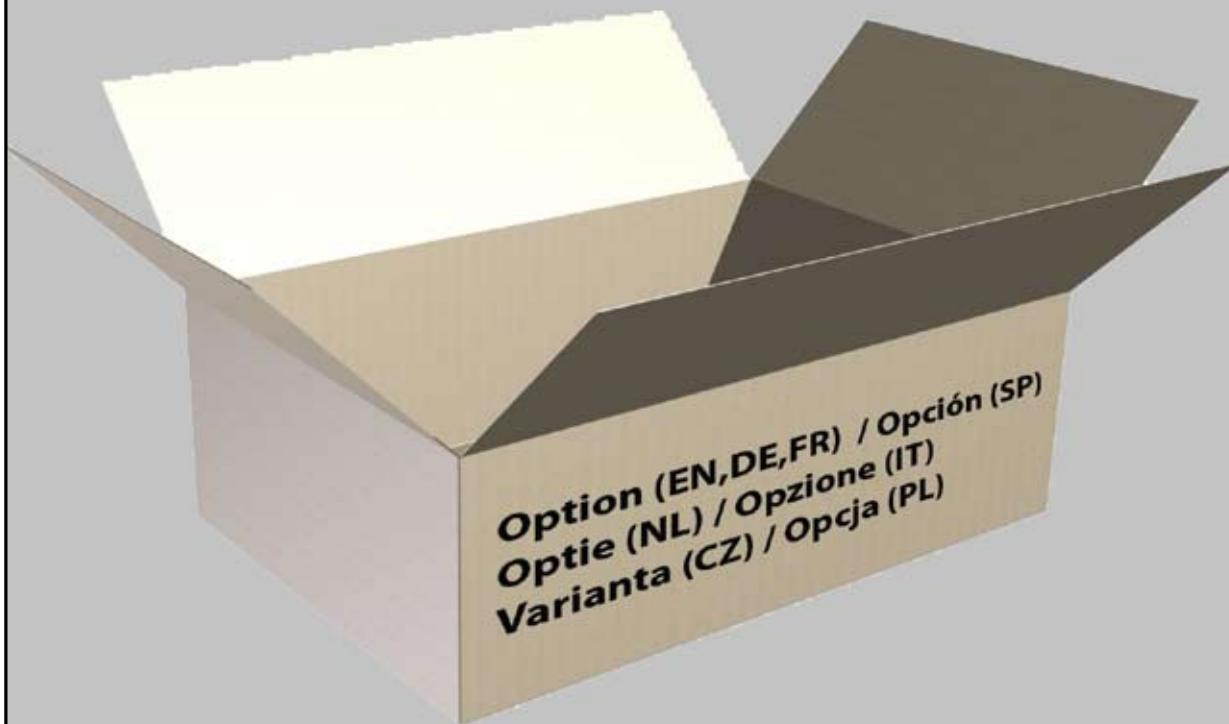

17.1

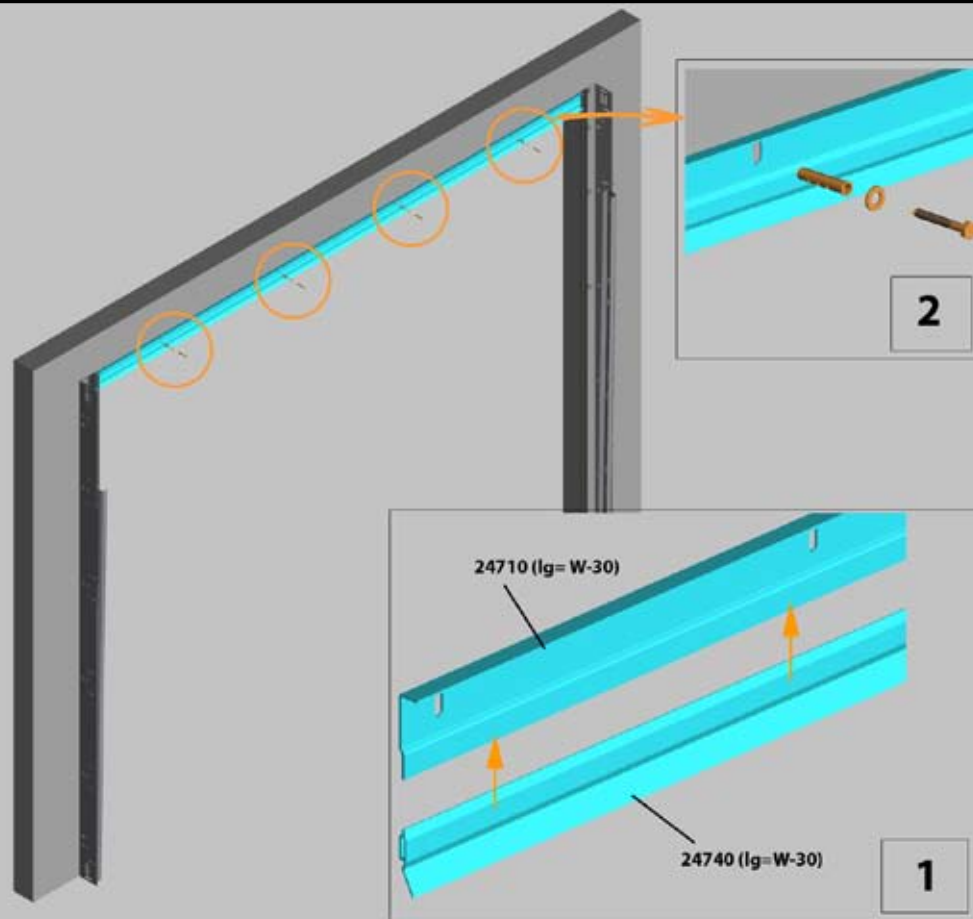

10. Handover

Handover the following documents to the end user:

- This manual (assembly, maintenance and disassembly)
- User guide
- Service manual
- Declaration of conformity (in accordance with EN-13241-1)
- Inform the end user how to handle in case of malfunctions

10.1. First use

The first use of the garage door has to be carried out by an installer. After that the users can be instructed.

For more information refer to the user guide.

11 Electric operator (optional)

Mount the operator according the supplier's manual.

 NOTE:

In case of power failure it should be possible to unlock the door using the emergency release from the operator .

The door leaf may only in that case, be operated with a handle.

If there is no second entrance to the garage, we recommend an external release lock (art 60011) be fitted.

 Do not fit a pull cord, shoot bolt or lock to an electrically operated door .

Ensure that the horizontal tracks are long enough for the electrically operator, this is with reference to the operator drawbar (see below).

In the event that the tracks are too short, a longer horizontal track kit should be used.

11.1 Operator settings

Adjustment to the operator should be carried out in accordance with the operator manufacturers manual.

Please note that our hardware kits have been CE approved for use with the operators specified in our ITT report and enclosure B. Should a different operator be chosen, then the installer must carry out a peak force analysis in accordance with EN 12445 and EN 12453.

12 Disassembly

The door should be disassembled in the reverse sequence to the assembly manual.

12.1 Disposal

All parts of this garage door can be easily disposed of.

Please consult your local authorities on this matter

13 Maintenance

In accordance with EU standards, sectional overhead doors should be checked, from the first time of use, based on the indicated service by the installer.

This inspection service has to be recorded written.

This inspection service should be carried out by an approved installer cq company.

Directly after installing:

- | | |
|---|--------------|
| 1) lubricate the tracks (advice: PTFE spray) | By Installer |
| 2) lubricate bearings, and rollers (advice: PTFE spray) | By Installer |
| 3) lubricate pins of the hinges from intermediate- and side-hinges (advice: PTFE spray) | By Installer |
| 4) lubricate sealing rubbers (advice: special rubber grease or talcum powder) | By Installer |

After 3 months:

- | | |
|--|--------------|
| 1) Re-tensioning springs (relaxation springs) | By Installer |
| 2) visual inspection | By Installer |

Every 6 months or every 750 door cycles:

- | | |
|--|----------|
| 1) remove debris from the door and surroundings | By: user |
| 2.lubricate the tracks (advice: PTFE spray) | By: user |
| 3.lubricate bearings, shafts and rollers (advice PTFE spray) | By: user |
| 4.lubricate pins of the hinges from intermediate- and side-hinges (advice: PTFE spray) | By: user |
| 5.lubricate sealing rubbers (advice: special rubber grease or talcum powder) | By: user |
| 6.clean the panels (advice: shampoo for car cleaning with water), do not use aggressive detergents | By: user |
| 7.wax the panels (advice: car wax) | By: user |

Every 12 months or every 1500 door cycles :

- | | |
|--|--------------|
| 1) check the cables, the end connections from the cable drums and bottom brackets on wear or damages | By Installer |
| 2.check the spring break devices in accordance with separate manual | By Installer |
| 3.check the balance of the door | By Installer |
| 4.check the pulley (if present) for wear or damages | By Installer |
| 5.check the rollers for wear and damages | By Installer |
| 6.check the closing forces of the main closing edge | By Installer |
| 7.check the suspension from the horizontal track to the ceiling | By Installer |
| 8.check the weather strips for wear or damages | By Installer |
| 9.check the bottom seal for wear or damages | By Installer |
| 10.check the rubber seals on the top panel for wear of damage | By Installer |
| 11.check the shaft coupler (if present) | By Installer |
| 12.lubricate the torsion springs | By Installer |